

EVENTUALLY, YOU MAY WANT TO REPLACE THIS PRODUCT:

Regulations require the recycling of Waste from Electrical and Electronic Equipment (European "WEEE Directive" effective August 2005—UK WEEE Regulations effective February 2014). Environment Agency Registered Producer: WEE/GA0248QZ.

When your product comes to the end of its life or you choose to replace it, please recycle it where facilities exist - do not dispose with household waste.

CLEANING:

Clean this fitting only with a soft dry cloth. Do not use any chemical or abrasive cleaners.

IF YOU EXPERIENCE PROBLEMS:

If you believe your product is defective, please return it to the place where you bought it. Our Technical Team will gladly advise on any Eterna Lighting product, but may not be able to give specific instructions regarding individual installations.

Specifications	
Operating voltage	220 ~ 240 VAC 50/60Hz
Rated load	400W (Capacitive load) 800W (Resistive load)
Stand-by power	<0.5W
Sensitivity	10% / 50% / 100% / Disable
Hold-time	5s / 90s / 5min / 15min
Daylight sensor	2lux / 10lux / 50lux / Disable
Microwave frequency	5.8 GHz +/- 75MHz
Transmitting power	<0.2mW
Detection range	Max. installation height: 6m Max. detection range: Ø 10m @ 3m installation height
Detection angle	30° ~ 150°
Working temperature	-20°C ~ 60°C
IP rating	IP20



RED DIRECTIVE - Microwave Occupancy Sensor
Full declaration available at:
www.eterna-lighting.co.uk/red-declaration

Huxley Close, Wellingborough, Northamptonshire, UK, NN8 6AB
Unit B4D, Airport Business Park, Cloghran, Co. Dublin, Ireland, K67X 7H9

Email: sales@eterna-lighting.co.uk / technical@eterna-lighting.co.uk
Visit our website: www.eterna-lighting.co.uk

Issue 0924

Made in China

eterna.

INSTALLATION INSTRUCTIONS



Scan QR code to go to web page

E04VSMS

Verus

On/Off Microwave Sensor

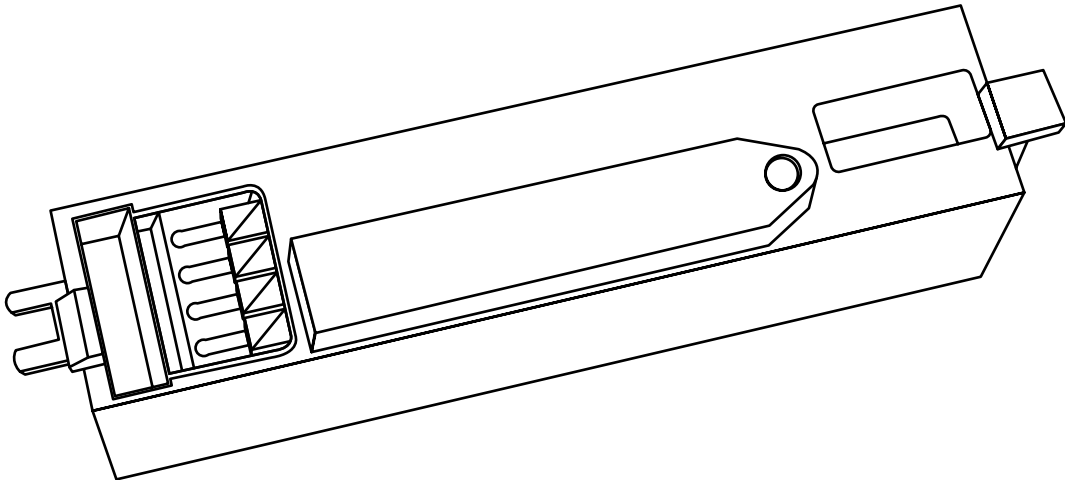

Pack contents: 1 x microwave sensor

A guide for qualified electricians

READ THIS FIRST:

Check the pack and make sure you have all of the parts listed on the front of this booklet. If not, contact the outlet where you bought this product.

This product must be installed by a competent person in accordance with the current building and IEE wiring regulations.

As the buyer, installer and/or user of this product it is your own responsibility to ensure that this fitting is fit for the purpose for which you have intended it. Eterna Lighting cannot accept any liability for loss, damage or premature failure resulting from inappropriate use.

This product is designed and constructed according to the principles of the appropriate British Standard and is intended for normal domestic service.

Switch off the mains before commencing installation and remove the appropriate circuit fuse or lock off MCB.

This product is not intended to be used by children and persons with sensory, physical and/or mental impairments that would prevent them from using it safely.

You are advised at every stage of your installation to double-check any electrical connections you have made. After you have completed your installation there are electrical tests that should be carried out, these tests are specified in the current IEE wiring and building regulations.

INTRODUCTION:

This is a microwave sensing device which continuously scans the operating zone and immediately switches the light on when it detects movement in that area. This means that whenever movement is detected within the range of the sensor the light will switch on automatically and illuminate the area you have selected to light. While there is movement within range of the unit the light will remain on.

HOW IT WORKS:

The microwave sensor is an active motion detector: it emits a high frequency electromagnetic wave 5.8GHz and receives its echo. The sensor detects the change in echo from movement in its detection zone. A microprocessor then triggers the switch light ON command. Detection is possible through doors, panels of glass and thin walls and thin walls and will continually monitor the signal within the detection area.

DETECTION RANGE:

See opposite page:

HOLD TIME:

Hold-time refers to the time period that the light remains 100% on if no more movement is detected.

DAYLIGHT SENSOR:

Different daylight threshold can be preset on DIP switches. Light will always turn on upon movement if daylight sensor is disabled.

Detection Area

	1	2	
I	●	●	100%
II	●	○	50%
III	○	●	10%
IV	○	○	Disable

Hold Time

	3	4	
I	●	●	5s
II	●	○	90s
III	○	●	5min
IV	○	○	15min

Daylight Sensor

	5	6	
I	●	●	Disable
II	●	○	50Lux
III	○	●	10Lux
IV	○	○	2Lux

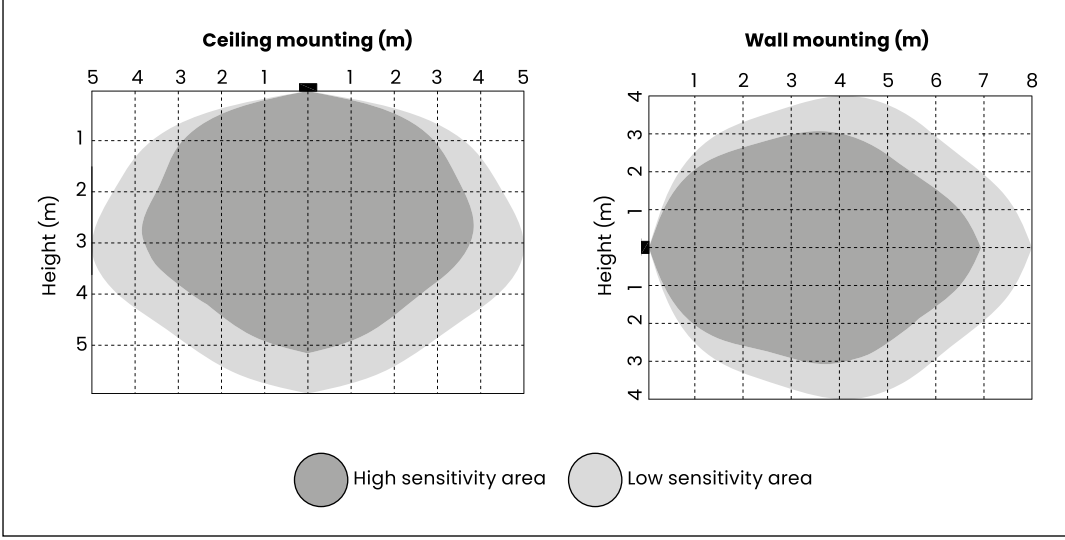
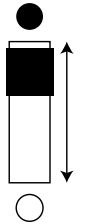

Verus microwave sensor installation wiring guide

Verus layout example

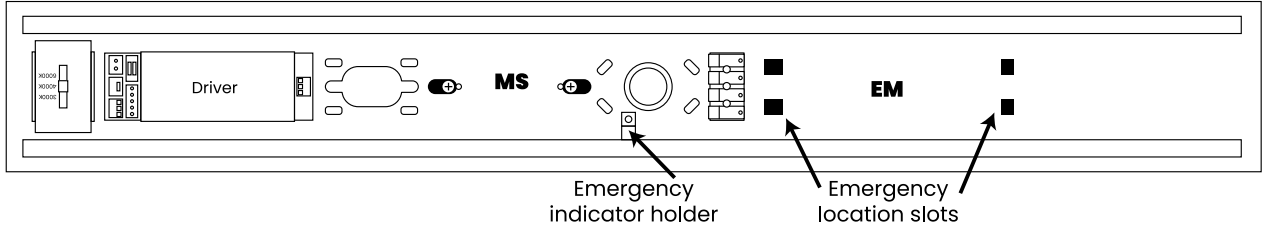

Step by step instructions

1

Turn off mains supply

2

Position the ends of the sensor into the pillars and then twist the retaining clips to hold in place

3

Disconnect the "SL" plug on the terminal block from the driver

4

Connect the microwave sensor plug to the "SL" plug on the terminal block and then connect the microwave sensor plug to the driver plug

5

Turn on mains supply

Verus full view wiring guide

Use cable tabs located down the whole length of the base of the unit to tidy and retain the cables once all connections are made

