

REPLACEMENT BATTERY TYPE:

6.4V 1500mAh LiFePO4 - replacement battery code: EB33

BATTERY REPLACEMENT:

If after routine operation check, the lamp does not remain lit for the three hour period, a new battery pack may be required.

- 1) Switch off the electricity at the mains and allow batteries to fully discharge then reconnect to supply and allow charging for 24 hours.
- 2) Test again for 3 hours, if light does not remain lit, then change the battery pack as follows:
 - 2a) Isolate from mains supply and unplug the battery plug lead from the socket and re-plug the new battery.
 - 2b) Restore power and allow charging for 24 hours.
 - 2c) Perform full operation check and update test record.

IMPORTANT NOTES:

The battery charging circuit and components are separated from the mains by at least basic (single layer) insulation.

When energised by a constant mains supply, the battery will be constantly charged whether or not the lamp is illuminated. On failure of the constant mains supply, the fitting will switch automatically using transistorised switching from battery charging to battery discharge powering the lamp whether or not the lamp was illuminated before the power failure.

EVENTUALLY, YOU MAY WANT TO REPLACE THIS PRODUCT:

Regulations require the recycling of Waste from Electrical and Electronic Equipment (European "WEEE Directive" effective August 2005—UK WEEE Regulations effective February 2014). Environment Agency Registered Producer: WEE/GA0248QZ.

When your product comes to the end of its life or you choose to replace it, please recycle it where facilities exist - do not dispose with household waste.

INDUSTRIAL BATTERIES:

Within certain products Eterna Lighting Ltd places lead acid, lithium ion, nickel cadmium & nickel metal hydride batteries on the market. Industrial batteries are subject to waste regulation under the Waste Batteries and Accumulators Regulations 2009 and should be disposed of responsibly. Purchasers may be able to dispose of their waste industrial batteries locally via legitimate licensed trade waste contractors. Eterna is obliged to take back, free of charge and within a reasonable time, waste industrial batteries of the same chemistry supplied to a Purchaser, for treatment and recycling and is required to do this in any calendar year new industrial batteries are placed on the market. In certain circumstances, this may include batteries not originally supplied by Eterna. If any Purchaser requires Eterna to take back Industrial batteries, they should write to the Operations Director, Eterna Lighting Ltd, Huxley Close, NN8 6AB, who will then advise on the necessary arrangements for the receipt, proper treatment and recycling of, the waste industrial batteries.

CLEANING:

Clean this fitting only with a soft dry cloth. Do not use any chemical or abrasive cleaners.

IF YOU EXPERIENCE PROBLEMS:

If you believe your product is defective, please return it to the place where you bought it. Our Technical Team will gladly advise on any Eterna Lighting product, but may not be able to give specific instructions regarding individual installations.

eterna.

INSTALLATION INSTRUCTIONS

E04VSEM

Verus

3W Emergency Pack



Scan QR code to go to web page

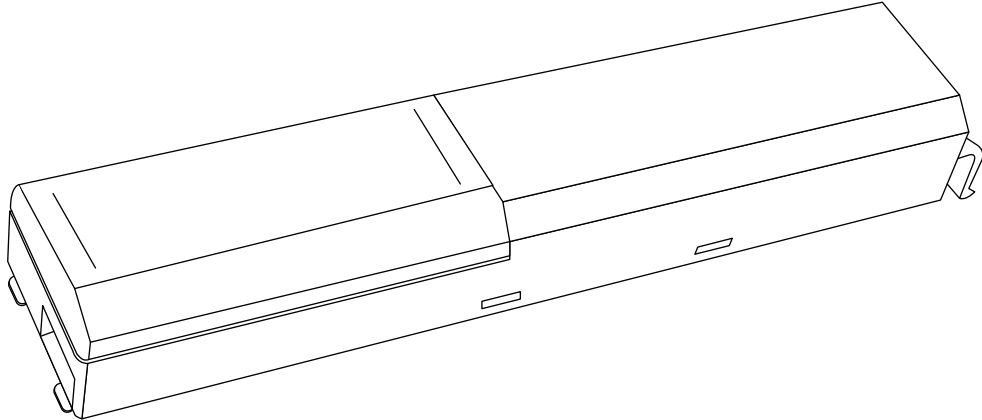

Huxley Close, Wellingborough, Northamptonshire, UK, NN8 6AB
Unit B4D, Airport Business Park, Cloghran, Co. Dublin, Ireland, K67X 7H9

Email: sales@eterna-lighting.co.uk / technical@eterna-lighting.co.uk
Visit our website: www.eterna-lighting.co.uk

Issue 0924

Made in China

Pack contents: 1 x Emergency battery pack

A guide for qualified electricians

READ THIS FIRST:

Check the pack and make sure you have all of the parts listed on the front of this booklet. If not, contact the outlet where you bought this product.

This fitting must be installed by a competent person in accordance with the current building and IEE wiring regulations.

As the buyer, installer and/or user of this product it is your own responsibility to ensure that this fitting is fit for the purpose for which you have intended it. Eterna Lighting cannot accept any liability for loss, damage or premature failure resulting from inappropriate use.

Switch off the mains before commencing installation and remove the appropriate circuit fuse or lock of MCB.

Disconnect from the electrical supply before flash or high voltage testing.

This unit is suitable for indoor use only.

Do not cover the fitting with any insulating materials.

You are advised at every stage of your installation to double-check any electrical connections you have made. After you have completed your installation there are electrical tests that should be carried out: these tests are specified in the Wiring Regulations (BS7671) referred to in the Building Regulations.

The batteries supplied with this fitting are a consumable part and therefore may be outside of any warranty offered.

OPERATION CHECKS:

Periodic testing should be carried out to ensure emergency lighting is operating correctly. Interruption of the supply, causing the fitting to be energised from the battery, should be carried out by the operation of a local keyswitch or other isolation device. During this period all fittings should be examined visually to ensure that they are functioning correctly. At the end of the test period the supply shall be restored and all indicator lamps or devices checked to ensure that the normal supply has been restored.

DAILY:

Visual inspection of the battery charge LED.

EACH MONTH:

Isolate the power supply for a period sufficient to ensure that each lamp is illuminated. Endorse the test record form supplied.

ONCE EACH YEAR:

Isolate the power supply and check that the light is still illuminated after 3 hours. Endorse the test record form.

Because of the possibility of a failure of the normal lighting supply occurring shortly after a period of testing of the emergency lighting system or during the subsequent recharge period, all full duration tests shall wherever possible be undertaken preceding time of low risk to allow for battery recharge.

NOTE: please keep this instruction booklet and the test record in a safe place. A fire officer or other authorised person may want to see your record of inspection and testing.

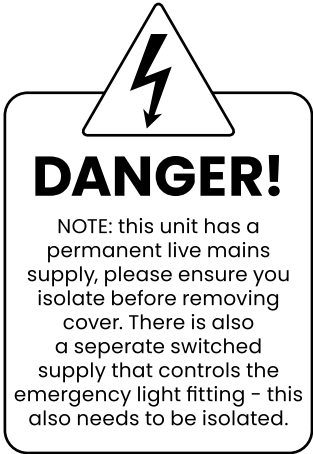

DANGER!

NOTE: this unit has a permanent live mains supply, please ensure you isolate before removing cover. There is also a separate switched supply that controls the emergency light fitting – this also needs to be isolated.

Verus emergency installation wiring guide

Verus layout example

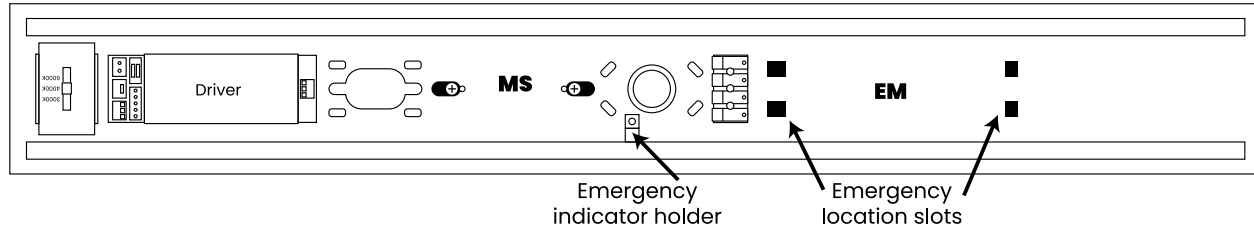

Step by step instructions

1

Turn off mains supply

2

Orientate the emergency pack to match the arrows on the fitting. Insert the pack arrow direction end first into the slots, then press on other side of the pack so the clips fit through the slots

3

Insert indicator in to the holder

4

Connect the emergency cable (white) to the 'PL' plug on the terminal block

5

Make sure the "SL" plug on the terminal block is connected to the driver input cable

6

Connect the red and white ribbon cable on the emergency pack to the plug on the driver

7

Insert battery and connect the cable to the battery pack. Ensure the plastic cover on the battery pack is closed

8

Label must be positioned to be visible on the outside of the fitting after installation

E04VSEM
Verus Plug Play 3W Standard
Emergency Pack
220~240VAC ~ 7.2VDC 50~60Hz
6.4V 1500mAh LifePO4 Battery
www/yy

TYPE	MODE	FACILITIES	DURATION
X	1		180

Eterna Lighting Ltd UK, NN8 6AB
Unit B4D, Airport Business Park, Cloghran, Co. Dublin, Ireland, K67X 7H9

Made in China

9

Turn on mains supply

Verus full view wiring guide

Use cable tabs located down the whole length of the base of the unit to tidy and retain the cables once all connections are made

