

## CLEANING:

Clean this fitting only with a soft dry cloth.  
Do not use any chemical or abrasive cleaners.

## BATTERY REPLACEMENT:

If after routine operation check, the lamp does not remain lit for the three hour period, a new battery pack may be required.

- Switch off the electricity at the mains (both permanent live and switch live) and allow batteries to fully discharge then reconnect to supply and allow charging for 24 hours.
- Test again for 3 hours, if light does not remain lit, then change the battery pack as follows:
- Remove the diffuser and remove the gear tray.
- Remove the battery case from the gear tray and remove the battery.
- Write current date on the new battery pack and fit a new battery by reversing the above procedure.
- Plug battery pack into circuit board.
- Refit gear tray and diffuser.
- Restore power and allow charging for 24 hours.
- Perform full operation check and update test record.

## REPLACEMENT BATTERY TYPE:

3.2V 1500mAh LiFePO4.

## STEP DIM MW SENSOR SPECIFICATIONS:

PRODUCT TYPE	STEP DIM MICROWAVE MOTION SENSOR
Operating Voltage	220-240VAC 50/60Hz
HF System	5.8GHz
Transmission Power	<0.2mW
Detection Angle	150° Max
Power Consumption	<0.3W
Detection Range	Max. 6m adjustable
Detection sensitivity	50% / 100%
Hold time	5s / 90s / 180s / 10 min
Corridor function	0s / 10s / 10 min / Disable
Corridor Dimming Level	10% / 30%
Daylight sensor	10 lux / Disable
Mounting	Indoors, ceiling and wall
Light Control	10lux, disable
Working Temp	-20 to +60 degree
Rated Load	400W (Inductive load) 800W (Resistive load) 270W (LED)

## EVENTUALLY, YOU MAY WANT TO REPLACE THIS PRODUCT:

Regulations require the recycling of Waste from Electrical and Electronic Equipment (European "WEEE Directive" effective August 2005—UK WEEE Regulations effective 2nd January 2007). Environment Agency Registered Producer: WEE/GA0248QZ.

WHEN YOUR PRODUCT COMES TO THE END OF ITS LIFE OR YOU CHOOSE TO REPLACE IT, PLEASE RECYCLE IT WHERE FACILITIES EXIST - DO NOT DISPOSE WITH HOUSEHOLD WASTE.

## INDUSTRIAL BATTERIES:

Within certain products Eterna Lighting Ltd places lead acid, lithium ion, nickel cadmium & nickel metal hydride batteries on the market. Industrial batteries are subject to waste regulation under the Waste Batteries and Accumulators Regulations 2009 and should be disposed of responsibly. Purchasers may be able to dispose of their waste industrial batteries locally via legitimate licensed trade waste contractors. Eterna is obliged to take back, free of charge and within a reasonable time, waste industrial batteries of the same chemistry supplied to a Purchaser, for treatment and recycling and is required to do this in any calendar year new industrial batteries are placed on the market. In certain circumstances, this may include batteries not originally supplied by Eterna. If any Purchaser requires Eterna to take back Industrial batteries, they should write to the Operations Director, Eterna Lighting Ltd, Huxley Close, NN8 6AB, who will then advise on the necessary arrangements for the receipt, proper treatment and recycling of, the waste industrial batteries.

## IF YOU EXPERIENCE PROBLEMS:

If you believe your product is defective, please return it to the place where you bought it. Our Technical Team will gladly advise on any Eterna Lighting product, but may not be able to give specific instructions regarding individual installations.

## LAMP REPLACEMENT:

**The light source is designed to last the lifetime of the luminaire.**

The light source contained in this luminaire shall only be replaced by the manufacturer, service agent or a similar qualified person.

**CAUTION, RISK OF ELECTRIC SHOCK.**



# Eterna

## Everyday Lighting For Professionals

## INSTALLATION INSTRUCTIONS

### A guide for qualified electricians



Eterna Lighting Ltd  
**RED DIRECTIVE - Microwave Occupancy Sensor**  
Full declaration available at:  
[www.eterna-lighting.co.uk/red-declaration](http://www.eterna-lighting.co.uk/red-declaration)

**NOTE: please keep this instruction booklet and the test record in a safe place. A fire officer or other authorised person may want to see your record of inspection and testing.**

**Pack contents:**  
1 x LED ceiling fitting • 1 x Fixing kit  
1 x Maintenance check record

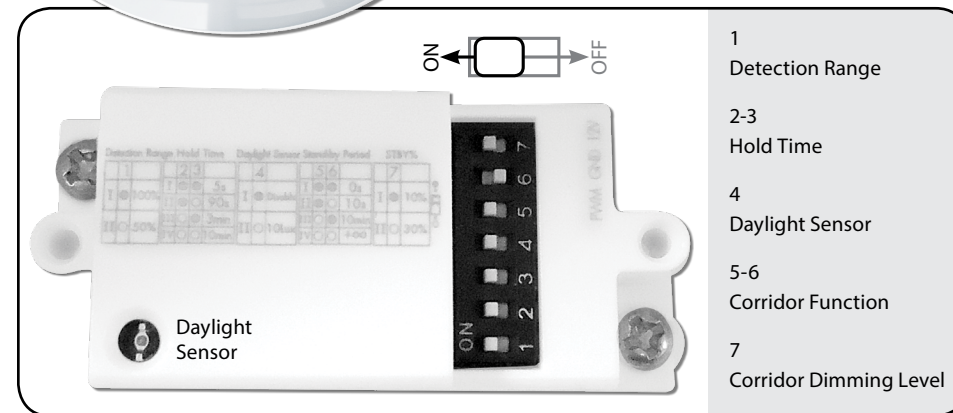

## Model:

# CHA18SDEM3

### Emergency Power and Colour Temperature Selectable Circular LED Ceiling/Wall Light With Step Dim Microwave Sensor

These instructions are provided as a guideline to assist you.

**PLEASE READ THESE INSTRUCTIONS BEFORE INSTALLATION  
AND RETAIN FOR FUTURE REFERENCE**

Email: [sales@eterna-lighting.co.uk](mailto:sales@eterna-lighting.co.uk) / [technical@eterna-lighting.co.uk](mailto:technical@eterna-lighting.co.uk)

Visit our website: [www.eterna-lighting.co.uk](http://www.eterna-lighting.co.uk)

Made in China

## READ THIS FIRST:

Check the pack and make sure you have all of the parts listed on the front of this booklet. If not, contact the outlet where you bought this product.

This product must be installed by a competent person in accordance with the current building and IEE wiring regulations.

As the buyer, installer and/or user of this product it is your own responsibility to ensure that this fitting is fit for the purpose for which you have intended it. Eterna Lighting cannot accept any liability for loss, damage or premature failure resulting from inappropriate use.

This product is designed and constructed according to the principles of the appropriate British Standards and is intended for normal domestic service. Using this fitting in any other environments may result in a shortened working life, for example where there is prolonged periods of use or higher than normal ambient temperatures such as lighting public or shared spaces or in nursing /care home facilities.

Switch off the mains before commencing installation and remove the appropriate circuit fuse or lock off MCB.

**WARNING:** There are two mains feed. Disconnect both before removing cover.

The batteries supplied with this fitting are consumable parts and therefore may be outside of any warranty offered.

This unit is suitable for indoor or outdoor use.

Ensure that the fitting will be accessible after installation for maintenance and self testing.

This product is suitable for use in living areas, Bathroom Zone 2 and outdoors of zones.

**If being fitted in a bathroom a 30mA RCD must be used.**

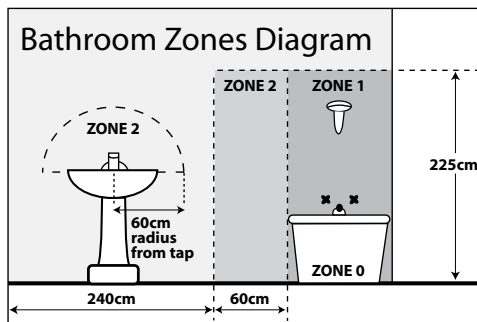

This product is designed for permanent connection to fixed wiring: this must be a suitable circuit (protected with the appropriate MCB or fuse).

This product is suitable for installation on surfaces with normal flammability e.g. wood, plasterboard and masonry. It is not suitable for use on highly flammable surfaces (e.g. polystyrene, textiles).

Before making fixing hole(s), check that there are no obstructions hidden beneath the mounting surface such as pipes or cables.

The chosen location of your new fitting should allow for the product to be securely mounted (e.g. to a ceiling joist) and safely connected to the mains supply (lighting circuit).

When making connections ensure that the terminals are tightened securely and that no strands of wire protrude. Check that the terminals are tightened onto the bared conductors and not onto any insulation.

**This product is double insulated. Do not connect any part to Earth.**

This product is not intended to be used by children and persons with sensory, physical and/or mental impairments that would prevent them from using it safely.

You are advised at every stage of your installation to double-check any electrical connections you have made. After you have completed your installation there are electrical tests that should be carried out, these tests are specified in the current IEE wiring and building regulations.

## INSTALLATION:

Choose the location for your new fitting according to the conditions listed opposite.

- Hold the base of the fitting and gently turn the diffuser and decorative trim anti-clockwise and lift off.
- Loosen screw on LED turnbuckle and rotate to release the tray which will then hinge to allow access to the wiring terminals.
- Drill holes in the back of your fitting for your fixing screws, take care and drill gently to ensure a clean hole through. Use a drill bit sized appropriately to your fixing screws.
- Using the back of your fitting as a template, mark the position of your fixing holes on your mounting surface.
- Prepare the holes in your mounting surface as appropriate for your fixings.
- Pierce the rubber grommet in the back of your fitting making a hole just large enough to make a tight fit around the incoming mains cable.
- Thread the cable through the grommet and offer the fitting to the ceiling / wall.
- Secure the fitting in place. Note, if protection against ingress of moisture is required, the heads of screws must be covered with a silicone or similar sealant.
- Check that the grommet is still correctly fitted in the cable entry hole and around the incoming cable.
- Make the electrical connections to the terminal block according to the markings:  
Brown to live (L) / Blue to neutral (N)
- Mark the current date on the battery pack.
- Ensure the battery plug is connected to the socket on the driver.
- Set power to the desired option by selecting appropriate switch setting on the driver:  
9W / 14W / 18W options

- Set colour temperature to the desired option by selecting appropriate switch setting on the driver.
- Set desired settings on microwave.
- Replace gear tray and secure in position
- Offer the diffuser and decorative trim onto the top of the fitting and turn clockwise until they are held securely.
- Restore the power and switch on.

**NOTE:** In warm white (3000K) and daylight white (6500K) operation only one set of LEDs will illuminate, in cool white (4400K) both sets of LEDs will illuminate.

DL	Daylight	6500K
CW	Cool White	4400K
WW	Warm White	3000K

**An Earth connection is not required for the operation of these Class II luminaires. The addition of the Earth terminal provides a loop-in/loop out facility which allows connectivity through to other Class I luminaires in the same lighting circuit.**

**NOTE: For non-maintained operation, remove link wire between PL and SL. For switched operation, remove link wire and connect switched supply into SL.**

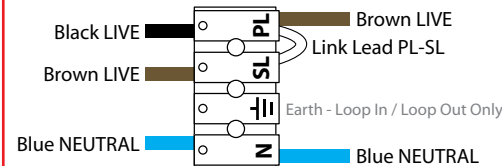

## OPERATION CHECKS:

Periodic testing should be carried out to ensure emergency lighting is operating correctly. Interruption of the supply, causing the fitting to be energised from the battery, should be carried out by the operation of a local keyswitch or other isolation device. During this period all fittings should be examined visually to ensure that they are functioning correctly. At the end of the test period the supply shall be restored and all indicator lamps or devices checked to ensure that the normal supply has been restored.

**DAILY:**  
Visual inspection of the battery charge LED.

**EACH MONTH:**  
Isolate the power supply for a period sufficient to ensure that each lamp is illuminated. Endorse the test record form supplied.

**ONCE EACH YEAR:**  
Isolate the power supply and check that the light is still illuminated after 3 hours. Endorse the test record form.

Because of the possibility of a failure of the normal lighting supply occurring shortly after a period of testing of the emergency lighting system or during the subsequent recharge period, all full duration tests shall wherever possible be undertaken preceding time of low risk to allow for battery recharge.

## UNDERSTANDING THE CONTROLS:

**REFER TO STEP DIM MICROWAVE SENSOR PICTURE ON FRONT PAGE / BELOW:**

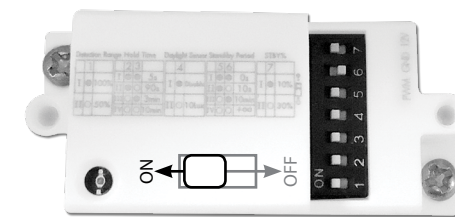

The motion detector can turn on the light based on movement. With this detector built in, light is automatically on when needed and dimmed to preset level before it is totally off.

## SENSITIVITY / DETECTION RANGE

Sensitivity can be adjusted by selecting the combination on the DIP switches for different applications.

	1	
I	ON	100%
II	OFF	50%

## HOLD-TIME

Hold-time refers to the time period that the light remains 100% on if no more movement is detected.

	2	3	
I	ON	ON	5sec
II	ON	OFF	90sec
III	OFF	OFF	180sec
IV	OFF	ON	10min

## DAYLIGHT SENSOR / THRESHOLD

Daylight threshold can be preset on DIP switches. Light will always turn on upon movement if daylight sensor is disabled.

	4	
I	ON	Disable
II	OFF	10Lux

## CORRIDOR FUNCTION / STAND-BY TIME

This is the time period that the light remains at a low level before it is completely turned off.

	5	6	
I	ON	ON	05sec
II	ON	OFF	10Sec
III	OFF	ON	10Min
IV	OFF	OFF	+∞

## CORRIDOR DIMMING LEVEL / STAND-BY DIMMING LEVEL

Light can be dimmed to different levels after hold-time.

	7	
I	ON	10%
II	OFF	30%



LED LAMP SPECIFICATIONS:	9W	14W	18W
<b>Luminaire lumens (with diffuser):</b> Warm White, Cool White, Daylight White	3000K - <b>1000 lm</b>	3000K - <b>1500 lm</b>	3000K - <b>1880 lm</b>
	4400K - <b>1100 lm</b>	4400K - <b>1670 lm</b>	4400K - <b>2130 lm</b>
	6500K - <b>1100 lm</b>	6500K - <b>1640 lm</b>	6500K - <b>2050 lm</b>
<b>Lumens from chip (array):</b> Warm White, Cool White, Daylight White	3000K - <b>1120 lm</b>	3000K - <b>1680 lm</b>	3000K - <b>2120 lm</b>
	4400K - <b>1220 lm</b>	4400K - <b>1880 lm</b>	4400K - <b>2400 lm</b>
	6500K - <b>1230 lm</b>	6500K - <b>1850 lm</b>	6500K - <b>2320 lm</b>
<b>Useful lumens (array):</b> Warm White, Cool White, Daylight White	3000K - <b>900 lm</b>	3000K - <b>1350 lm</b>	3000K - <b>1700 lm</b>
	4400K - <b>1000 lm</b>	4400K - <b>1500 lm</b>	4400K - <b>1900 lm</b>
	6500K - <b>1000 lm</b>	6500K - <b>1480 lm</b>	6500K - <b>1860 lm</b>
Rated Wattage	9W	14W	18W
Rated luminous flux	3000K - 900 lm	3000K - 1350 lm	3000K - 1700 lm
	4400K - 1000 lm	4400K - 1500 lm	4400K - 1900 lm
	6500K - 1000 lm	6500K - 1480 lm	6500K - 1860 lm
Nominal life time of the lamp	40,000 hrs	40,000 hrs	40,000 hrs
Colour temperature	3000/4400/6500K	3000/4400/6500K	3000/4400/6500K
Number of switching cycles before premature lamp failure	15000	15000	15000
Warm-up time up to 60% of the full light output	Instant full light	Instant full light	Instant full light
Dimmable	No	No	No
Nominal beam angle	120°	120°	120°
Rated power	9W	14W	18W
Rated lamp lifetime	40,000 hrs	40,000 hrs	40,000 hrs
Displacement factor	0.96	0.96	0.96
Lumen maintenance factor at end of nominal life	≥80	≥80	≥80
Starting time	Instant full light	Instant full light	Instant full light
Colour rendering	≥80	≥80	≥80
Colour consistency	Within 6 step Macadam ellipse	Within 6 step Macadam ellipse	Within 6 step Macadam ellipse
Rated peak intensity	3000K - 286cd	3000K - 432cd	3000K - 611cd
	4400K - 310cd	4400K - 484cd	4400K - 621cd
	6500K - 312cd	6500K - 746cd	6500K - 605cd
Rated beam angle	120°	120°	120°
Voltage / Frequency	240V~50-60Hz	240V~50-60Hz	240V~50-60Hz
Lumen efficacy	3000K - 111 lm / W	3000K - 107 lm / W	3000K - 104 lm / W
	4400K - 122 lm / W	4400K - 119 lm / W	4400K - 118 lm / W
	6500K - 122 lm / W	6500K - 117 lm / W	6500K - 114 lm / W
This product contains a Light Source of Energy Efficiency Class E			
Not suitable for accent lighting			

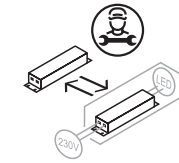
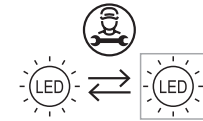

See website for more information on replacability and recycling