

EVENTUALLY, YOU MAY WANT TO REPLACE THIS PRODUCT:

Regulations require the recycling of Waste from Electrical and Electronic Equipment (European "WEEE Directive" effective August 2005—UK WEEE Regulations effective February 2014). Environment Agency Registered Producer: WEE/GA0248QZ.

When your product comes to the end of its life or you choose to replace it, please recycle it where facilities exist - do not dispose with household waste.

CLEANING:

Clean this fitting only with a soft dry cloth. Do not use any chemical or abrasive cleaners.

IF YOU EXPERIENCE PROBLEMS:

If you believe your product is defective, please return it to the place where you bought it. Our Technical Team will gladly advise on any Eterna Lighting product, but may not be able to give specific instructions regarding individual installations.

LED LAMP SPECIFICATIONS	2ft	4ft	5ft
Luminaire lumens	20W 2400lm	25W 3105lm	35W 4540lm
Colour temperature	4000K		
Nominal life time of the lamp	50,000 hrs		
Number of switching cycles before premature lamp failure	25,000		
Warm-up time up to 60% of the full light output	Instant		
Dimmable	No		
Nominal beam angle	120°		
Displacement factor	0.9		
Lumen maintenance factor at end of nominal life	0.7		
Colour rendering	80		
Colour consistency	<6		
Rated peak intensity	720cd	940cd	1467cd
Rated beam angle	120°		
Voltage / frequency	110V~ 50Hz		
Lumen efficacy	120 lm / W		
This product contains a light source of energy efficiency class D			
Not suitable for accent lighting			

eterna.

INSTALLATION INSTRUCTIONS



Scan QR code to go to web page

110V Weatherproof Batten

E14WP2F 110V 20W 4000K 2ft Weatherproof

E14WP4F 110V 25W 4000K 4ft Weatherproof

E14WP5F 110V 35W 4000K 5ft Weatherproof

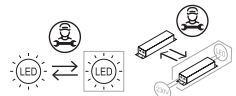
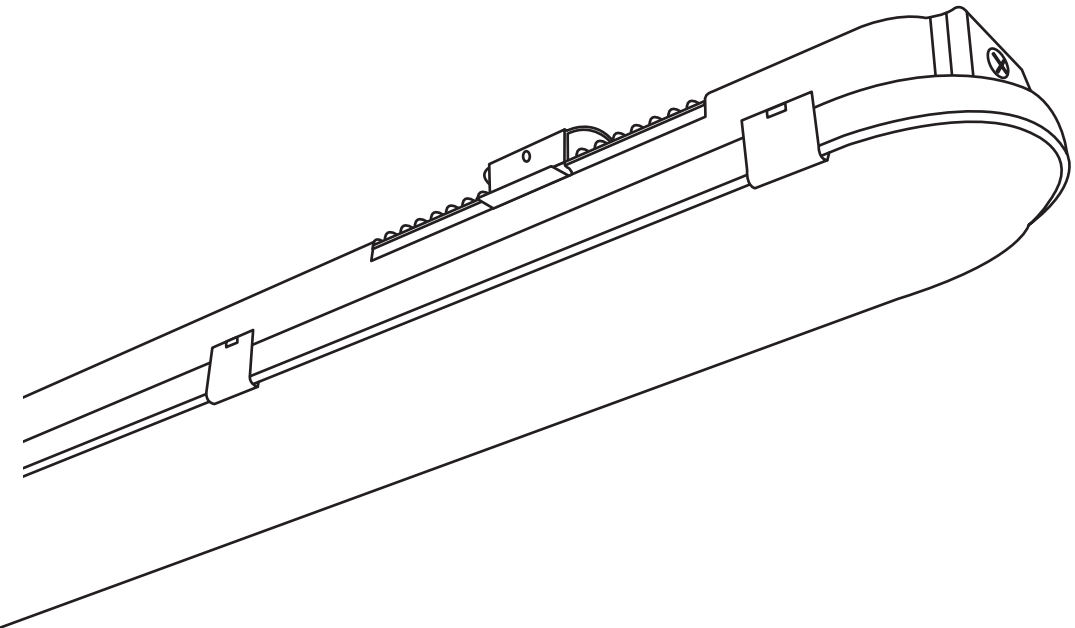

Huxley Close, Wellingborough, Northamptonshire, UK, NN8 6AB
Unit B4D, Airport Business Park, Cloghran, Co. Dublin, Ireland, K67X 7H9

Email: sales@eterna-lighting.co.uk / technical@eterna-lighting.co.uk
Visit our website: www.eterna-lighting.co.uk

Issue 1124

Made in China

Pack contents: 1 x LED batten, Fixing kit - 1 x cable gland, 2 x suspension hooks, 2 x sliding brackets, 4 x wall plugs & 4 x screws

A guide for qualified electricians

1

Turn off mains power and ensure supply is isolated

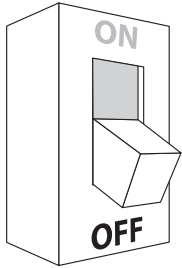

2

Lift all clips with a screw driver to release the diffuser. The retaining straps within the fitting allow you to suspend the diffuser during installation

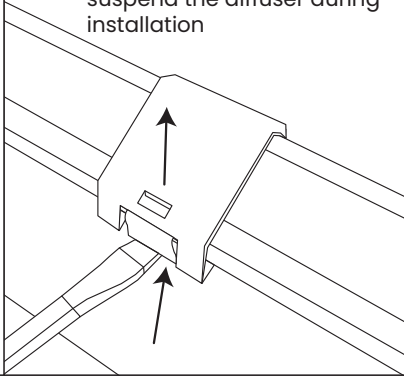

3

Cable entry is available at each end of the fitting, these are pre-drilled and capped.

Remove the cap from the fitting and the nut from the cable gland. Screw the cable gland into the threaded internal bracket.

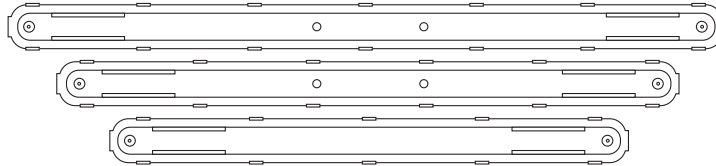

4

BESA mounting or suspension can be achieved using the brackets and suspension hooks provided

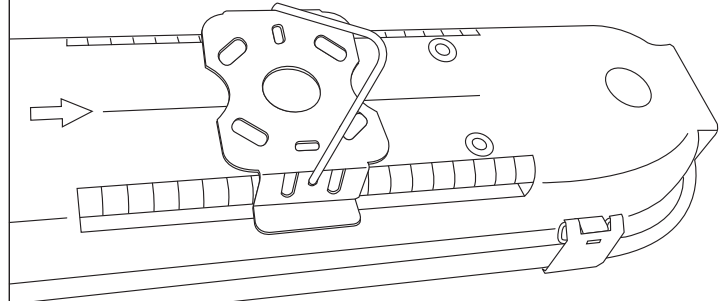

5

Make the connections from the mains cable to the push fit terminal block and secure fitting into place using suitable fixings. Ensure cables are not trapped behind or inside the fitting

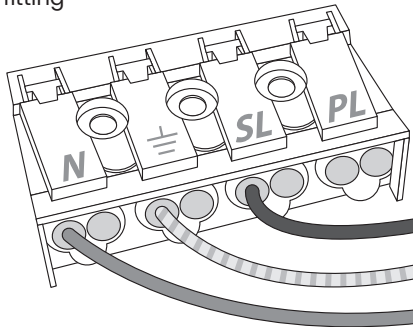

'PL' is to be used if using the emergency pack

6

Replace all clips to secure the diffuser in place

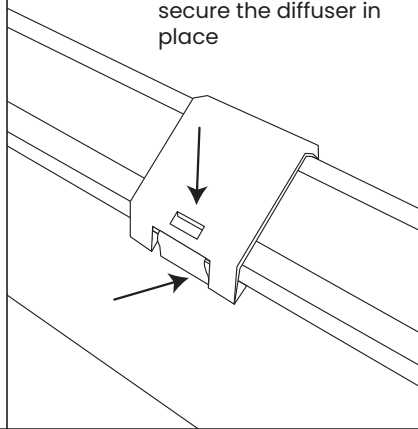

7

Turn on mains supply and test fitting

