

Installation Instructions

Instrucciones de instalación, Instructions d'installation, Installationsanleitung, إرشادات التركيب, Installatie-instructies, Instruções de instalação, Installatie-instructies, 設置手順説明, Οδηγίες εγκατάστασης



Warranty Information

Garantie, Información sobre la garantía, Garantieinformationen, معلومات الضمان, Garantie-informatie, Informações sobre a garantia, Garantie-informatie, 保証情報

Πληροφορίες εγγύησης

nl-NL	nl-BE	pt-PT	el-GR	js-JP
<p>Voor garantie-informatie kunt u contact opnemen met uw lokale vertegenwoordiger, of bezoek op onze website: www.anselluk.com</p> <p>We raden met klem aan om de installatie en/of het onderhoud van alle lichtarmaturen van Ansell door een gediplomeerd elektricien te laten uitvoeren en ervoor te zorgen dat de bedrading overeenstemt met de meest recente IEC-normen of het landelijk ke equivalent.</p> <p>De netvoeding moet tijdens installatie of onderhoud uitgeschakeld zijn.</p> <p>Als het product tijdens de garantieperiode defect raakt, zal Ansell het betreffende product repareren of vervangen.</p> <p>Ansell kan niet aansprakelijk worden gesteld voor installatiekosten die zij n verbanden aan vervanging van dit product.</p> <p>NB – De garantieperiode komt te vervallen en is ongeldig in de volgende omstandigheden: Wanneer de installateur, eindgebruiker of iemand anders nalaat om een bedekt product of onderdeel te beschermen tegen schade van buitenaf, te hoge of te lage temperaturen, vochtige omstandigheden, fluctuaties in het elektrische systeem of fysiek misbruik en tevens in geval van defecten gerelateerd aan slecht vakmanschap tijdens de installatie van de producten of onderdelen. Wanneer geen j juiste productinformatie kan worden verstrekt. Als u vragen of zorgen over het product heeft, dient u contact op te nemen met uw lokale vertegenwoordiger.</p>	<p>Voor garantie-informatie kunt u uw lokale vertegenwoordiger contacteren of onze website www.anselluk.com bezoeken</p> <p>Het wordt ten zeerste aanbevolen dat alle Ansell-verlichting wordt geïnstalleerd en onderhouden door een gekwalificeerde elektricien en bekabeld wordt overeenkomstig de geldende IEC-normen of een nationaal equivalent.</p> <p>De netspanning moet tijdens de installatie of het onderhoud worden uitgeschakeld.</p> <p>Als het product tijdens de garantieperiode defect raakt, zal Ansell het herstellen of vervangen.</p> <p>Ansell aanvaardt geen enkele aansprakelijkheid voor installatiekosten in verband met de vervanging van dit product.</p> <p>Let op - De garantie geldt niet in de volgende omstandigheden: Nalatigheid of onzorgvuldigheid van de installateur, de eindgebruiker of een derde bij het beschermen van een gedekt product of onderdeel tegen schade van buitenaf, ongunstige omstandigheden, schommelingen in het elektrische systeem of fysiek verkeerd gebruik, alsmede storingen die verband houden met slecht vakmanschap bij de installatie van de producten of onderdelen. Niet in staat zij n om correcte productinformatie te verstrekken. Als u vragen of opmerkingen heeft over het product, contacteer dan uw lokale vertegenwoordiger</p>	<p>Para obter informações sobre a garantia, contacte o seu representante local ou visite o nosso site web em www.anselluk.com</p> <p>Recomendamos vivamente que todas as lâmpadas da Ansell sejam instaladas/manidas por um electricista qualificado e a respetiva ligação elétrica efetuada de acordo com as normas IEC ou equivalente nacional mais recentes.</p> <p>A ligação à rede elétrica deve ser desativada durante os trabalhos de instalação ou manutenção.</p> <p>Se o produto apresentar alguma falha durante o período de garantia, a Ansell repara ou substitui o produto afetado.</p> <p>A Ansell não se responsabiliza por eventuais custos de instalação associados à substituição deste produto.</p> <p>Nota: o período de garantia é considerado nulo e sem efeito nas circunstâncias seguintes: Falta de cuidado por parte do instalador, utilizador final ou terceiros em proteger qualquer produto ou componente abrangido contra danos externos, níveis de temperatura adversos, condições de humidade, flutuações no sistema elétrico ou agressão física, assim como falhas relacionadas com uma execução deficiente na instalação dos produtos ou dos componentes. Incapacidade para fornecer informações corretas sobre os produtos. Em caso de dúvidas ou preocupações respeitantes ao produto, contacte o seu representante local.</p>	<p>Για πληροφορίες σχετικά με την εγγύηση, επικοινωνήστε με τον τοπικό σας αντιπρόσωπο ή επισκεφτείτε την ιστοσελίδα μας στη διεύθυνση www.anselluk.com</p> <p>Συνιστάται ιδιαίτερα όλα τα φωτιστικά Ansell να εγκαθίστανται / συντηρούνται από πλήρως εξειδικευμένο ηλεκτρολόγο και η καλωδίωση τους να γίνεται σύμφωνα με τα τελευταία πρότυπα IEC ή αντίστοιχα εθνικά πρότυπα.</p> <p>Η τροφοδοσία από το δίκτυο ηλεκτροδότησης πρέπει να απενεργοποιείται κατά τη διάρκεια οποιασδήποτε εγκατάστασης ή συντήρησης.</p> <p>Σε περίπτωση που το προϊόν πάθει βλάβη κατά τη διάρκεια της περιόδου εγγύησης, η Ansell θα επισκευάσει ή θα αντικαταστήσει το εν λόγω προϊόν.</p> <p>Η Ansell δεν φέρει καμία ευθύνη για οποιαδήποτε έσοδα εγκατάστασης που σχετίζονται με την αντικατάσταση αυτού του προϊόντος.</p> <p>Σημειώτων - Η περίοδος εγγύησης θα ακυρωθεί στις παρακάτω περιπτώσεις: Εάν ο υπεύθυνος εγκατάστασης, ο τελικός χρήστης ή οποιοσδήποτε τρίτος δεν έχει επιδείξει προσοχή για να προστατεύσει οποιοδήποτε καλυπτόμενο προϊόν ή εξάρτημα από εξωτερικές ζημιές, δυσμενείς συνθήκες θερμοκρασίας, υγρασίας, διακυμάνσεις στο ηλεκτρικό σύστημα ή φυσική κακομεταχείριση καθώς και βλάβη που σχετίζεται με κακής ποιότητας κατασκευή στην εγκατάσταση των προϊόντων ή εξαρτημάτων. Αδυναμία παροχής σωστών πληροφοριών για το προϊόν. Για οποιαδήποτε ερώτηση ή απορία σχετικά με το προϊόν, επικοινωνήστε με τον τοπικό σας αντιπρόσωπο.</p>	<p>保証の詳細についてはお近くの担当者にお問い合わせいただくか、弊社のウェブサイト www.anselluk.com をご覧ください。</p> <p>Ansell の照明器具は、設置/メンテナンスを適切な資格を有する電気技師が行い、最新の IEC 規格または同等の国家規格に従って配線することが強く推奨されます。</p> <p>設置作業時やメンテナンス作業時には必ず主電源を切ってください。</p> <p>保証期間内に製品が故障した場合、Ansell が当該製品を修理または交換いたします。</p> <p>Ansell は、当該製品の交換で発生するいかなる設置費用も、負担する責任を負いません。</p> <p>注意 – 保証期間は次の条件において無効になります: 設置者、エンドユーザー、または第三者が、保証対象製品またはその部品を、外的損傷、有害な温度、湿度条件、電気系統変動、または乱暴な扱いから保護するための注意を怠った場合、および、製品や部品の設置作業の粗雑さに起因する故障の場合。正確な製品情報をご提示いただけない場合、製品についてご不明な点がございましたら、お近くの担当者にお問い合わせください。</p>

Ansell Electrical Products
Unit 6B, Stonecross Industrial
Park,
Yew Tree Way,
Warrington,
WA3 3JD

Ansell (Sales & Distribution)
Unit 2, M2 Business Park,
Duncrue Street,
Belfast,
BT3 9AQ

Ansell (Sales & Distribution) Republic of Ireland Limited
Unit G1, Block G,
Calmount Park, Calmount Avenue
Dublin 12,
D12 TH56



Warrington Tel: +44 (0)1942 433333

Belfast Tel: +44 (0)2890 773750

International Tel: +44 (0)1942 433343

Spain Tel: 00 34 938 005642

Installation Instructions

Instrucciones de instalación, Instructions d'installation, Installationsanleitung, إرشادات التركيب, Installatie-instructies, Instruções de instalação, Installatie-instructies, 設置手順説明, Οδηγίες εγκατάστασης



Warranty Information

Garantie, Información sobre la garantía, Garantieinformationen, معلومات الضمان, Garantie-informatie, Informações sobre a garantia, Garantie-informatie, 保証情報

Πληροφορίες εγγύησης

GB	FR	ES	DE	AR
<p>For warranty details please contact your local representative or visit our website: www.anselluk.com</p> <p>It is highly recommended that all Ansell luminaires are installed / maintained by a fully qualified electrician and wired in accordance to the latest IEC standards or national equivalent.</p> <p>Mains power must be switched off during any installation or maintenance.</p> <p>Should the product fail during the warranty period, Ansell will repair or replace the product in question.</p> <p>Ansell do not accept any responsibility for any installation costs associated to the replacement of this product.</p> <p>"Please Note - The warranty period shall be null and void in the following circumstances: Failure by the installer, end user or any third party to exercise caution to protect any covered product or part from outside damage, adverse temperature, humidity conditions, fluctuations in the electrical system or physical abuse as well as failure related to poor workmanship in the installation of the products or parts. Inability to provide correct product information. Any questions or concerns with the product, please contact your local representative."</p>	<p>Pour connaître les détails de la garantie, veuillez contacter votre représentant local ou consulter notre site internet www.anselluk.com</p> <p>Il est fortement recommandé que l'installation et l'entretien de tous les luminaires Ansell soient effectués par un électricien qualifié et que leur raccordement soit conforme aux dernières normes IEC ou leur équivalent national.</p> <p>L'alimentation secteur doit être coupée pendant toute installation ou opération de maintenance.</p> <p>En cas de défaillance du produit pendant la période de garantie, Ansell réparera ou remplacera le produit en question.</p> <p>Ansell décline toute responsabilité associée au remplacement de ce produit.</p> <p>"Veuillez noter que la période de garantie est nulle et non avenue dans les cas suivants : Un manquement de la part de l'installateur, de l'utilisateur final ou d'un tiers en matière de protection de tout produit ou toute pièce couvert contre les dommages extérieurs, les températures néfastes, l'humidité, les fluctuations du système électrique ou les chocs physiques ainsi que des défaillances liées à une mauvaise exécution de l'installation des produits ou pièces. Incapacité à fournir des informations correctes sur le produit. Pour toute question ou inquiétude relative au produit, veuillez contacter votre représentant."</p>	<p>Para consultar información sobre la garantía, póngase en contacto con su representante local o visite nuestro sitio web: www.anselluk.com</p> <p>Se recomienda que todas las luminarias de Ansell sean instaladas / mantenidas por un electricista cualificado y cableado según las últimas normas IEC o su equivalente nacional.</p> <p>La corriente eléctrica debe estar desconectada durante todas las tareas de instalación o mantenimiento.</p> <p>Si el producto dejase de funcionar durante el periodo de garantía, Ansell reparará o reemplazará el producto en cuestión.</p> <p>Ansell no acepta ninguna responsabilidad por cualquier coste de instalación relacionado con el reemplazo del producto.</p> <p>"Tenga en cuenta que el periodo de garantía quedará invalidado en las siguientes circunstancias: Si el instalador, usuario final o cualquier otro tercero no tiene precaución para proteger cualquier producto o repuesto bajo garantía de daños externos, temperaturas perjudiciales, condiciones de humedad, cambios en el sistema eléctrico o maltrato físico, además de cualquier fallo debido a un deficiente trabajo o de instalación de los productos o los repuestos. Si no se puede facilitar la información correcta del producto. Si tiene alguna pregunta o duda sobre el producto, póngase en contacto con su representante local."</p>	<p>Für Garantieinformationen wenden Sie sich bitte an Ihren lokalen Vertreter oder besuchen Sie unsere Website www.anselluk.com</p> <p>Es wird dringend empfohlen, dass alle Ansell-Leuchten von einem Elektrofachmann installiert/gewartet und in Übereinstimmung mit der neusten IEC-Norm oder der entsprechenden nationalen Norm verdrahtet werden.</p> <p>Die Netzspannung muss bei der Installation oder Wartung abgeschaltet sein.</p> <p>Wenn das Produkt innerhalb der Garantiezeit versagt, repariert oder ersetzt Ansell das fragile Produkt.</p> <p>Wenn das Produkt innerhalb der Garantiezeit versagt, repariert oder ersetzt Ansell das fragile Produkt.</p> <p>"Bitte beachten Sie – Die Garantie erlischt unter folgenden Bedingungen: Der Installateur, Endnutzer oder ein Dritter lässt nicht die nötige Vorsicht walten, um ein durch die Garantie abgedecktes Produkt bzw. Teil vor äußerlicher Beschädigung, widrigen Temperaturen, Feuchtigkeitsbedingungen, Stromschwankungen oder unsachgemäßem Gebrauch zu schützen sowie bei Defekt durch mangelhafte Ausführung der Installation des Produktes oder seiner Teile. Unfähigkeit, korrekte Produktinformationen zur Verfügung zu stellen. Wenden Sie sich bei Fragen oder Bedenken zum Produkt bitte an Ihren lokalen Vertreter."</p>	<p>لمعرفة تفاصيل الضمان، الرجاء الاتصال بالممثل المحلي بمنطقة أو تفضل بزيارة موقعنا الإلكتروني: www.anselluk.com</p> <p>يوصى بشدة بأن يقوم تركيب وصيانة جميع منتجات Ansell في كهرتقني مؤهل بالكامل مع توصيل كابلاتها وإسلاكها طبقاً لأحدث معايير اللجنة الكهروتقنية الدولية (IEC) أو ما يعادلها من معايير وطنية.</p> <p>يجب فصل الطاقة (الكهرباء) الرئيسية أثناء أي أعمال تركيب أو صيانة.</p> <p>إذا فشل المنتج خلال فترة الضمان فسوف تقوم Ansell بإصلاحه أو استبداله.</p> <p>لا تقبل Ansell تحمل أي مسؤولية عن أي تكاليف تركيب باستبدال هذا المنتج.</p> <p>"الرجاء ملاحظة - تبطل فترة الضمان وتلغى في الحالات التالية: فشل القائم بالتركيب، أو المستخدم النهائي أو أي طرف ثالث (غيره) في توخي الحرص اللازم لحماية أي منتج معطى أو قطعة معطاة من الأضرار الخارجية أو درجة الحرارة المعاكسة أو ظروف الرطوبة أو التلوثات في النظام الكهرتقني أو الاعتداء المادي وتلك الفشل المرتبط بسوء الحرفة (الصناعة) في عملية تركيب المنتجات أو القطع. عدم القدرة على تقديم معلومات صحيحة تتعلق بالمنتج، بالنسبة لأي أسئلة أو استفسارات أو شواغل تتعلق بالمنتج، يرجى الاتصال بالممثل المحلي بمنطقة."</p>

Ansell Electrical Products
Unit 6B, Stonecross Industrial
Park,
Yew Tree Way,
Warrington,
WA3 3JD

Ansell (Sales & Distribution)
Unit 2, M2 Business Park,
Duncrue Street,
Belfast,
BT3 9AQ

Ansell (Sales & Distribution) Republic of Ireland Limited
Unit G1, Block G,
Calmount Park, Calmount Avenue
Dublin 12,
D12 TH56



Warrington Tel: +44 (0)1942 433333

Belfast Tel: +44 (0)2890 773750

International Tel: +44 (0)1942 433343

Spain Tel: 00 34 938 005642

Installation Instructions

Instrucciones de instalación, Instructions d'installation, Installationsanleitung, إرشادات التركيب,
 Installatie-instructies, Instruções de instalação, Installatie-instructies,
 設置手順説明, Οδηγίες εγκατάστασης



Product Code:[AKAR /1/]

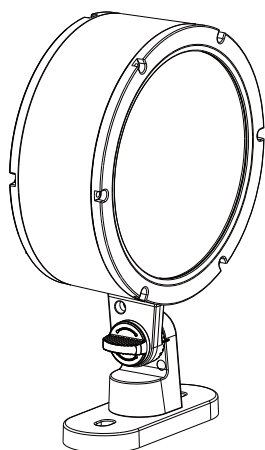
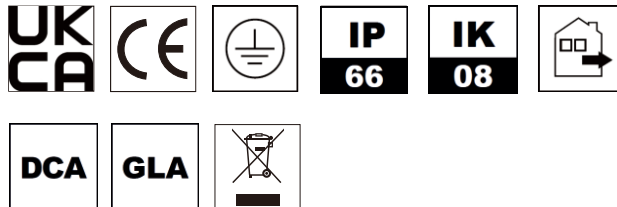
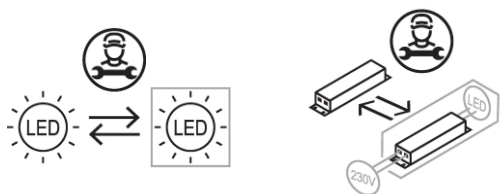

35W

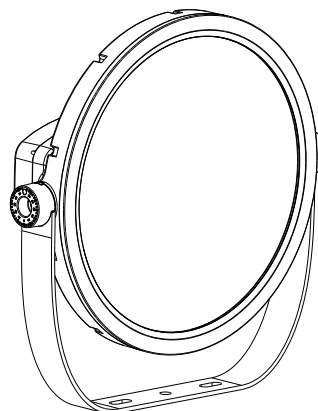

100W/150W

Packing List	
Safety Rope	1 PCS



Physical Dimensions(Unit: mm/inch)

35W

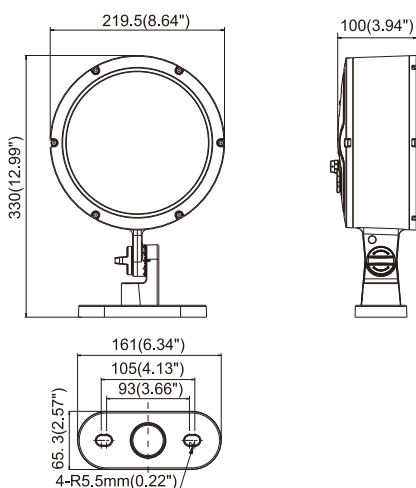

100W/150W

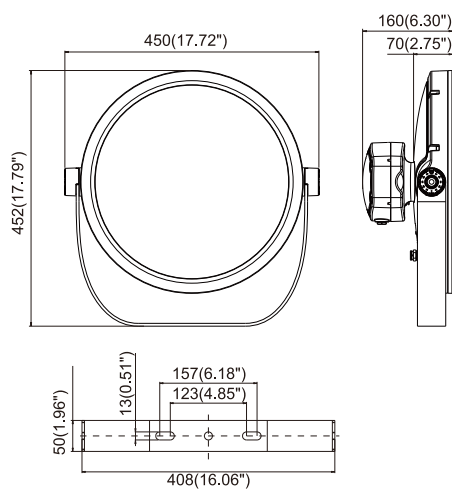

Ansell Electrical Products
 Unit 6B, Stonecross Industrial
 Park,
 Yew Tree Way,
 Warrington,
 WA3 3JD

Ansell (Sales & Distribution)
 Unit 2, M2 Business Park,
 Duncrue Street,
 Belfast,
 BT3 9AQ

Ansell (Sales & Distribution) Republic of Ireland Limited
 Unit G1, Block G,
 Calmount Park, Calmount Avenue
 Dublin 12,
 D12 TH56



Warrington Tel: +44 (0)1942 433333

Belfast Tel: +44 (0)2890 773750

International Tel: +44 (0)1942 433343

Spain Tel: 00 34 938 005642

Mounting

1. ✖ 35W
 Mounting height of the lamp should not exceed 15m.
 Recommended screw size: M10

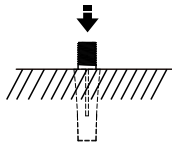

2. ✖

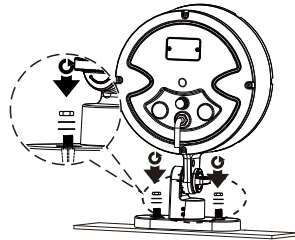

100W/150W
 Mounting height of the lamp should not exceed 15m.
 Recommended screw size: M12

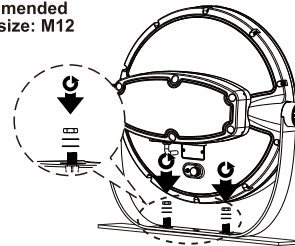

Rotation angle

When adjusting the angle, please hold the lamp body by hand to prevent it from falling.



Loosen here to adjust the angle.

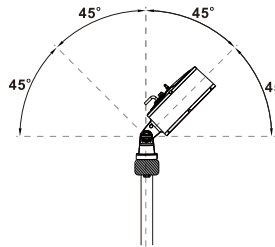
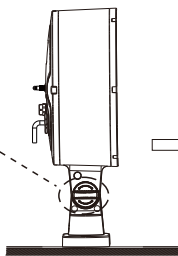

35W

2

1.2Nm

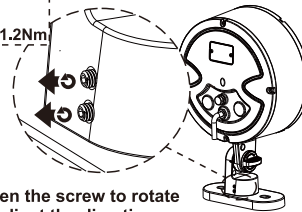

Loosen the screw to rotate and adjust the direction.

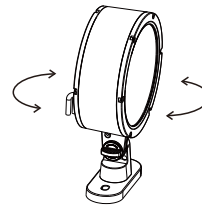

A 2Nm
B 17Nm

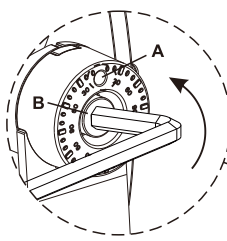

1. Loosen screw A (M5)
 2. Loosen screw B (M10)
 3. Adjust the angle

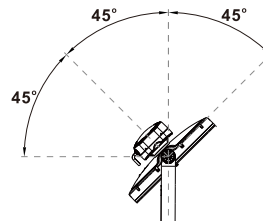
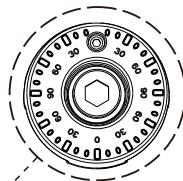
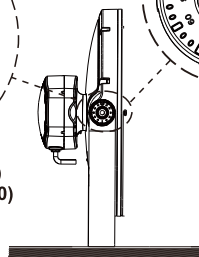

100W/150W

Safety rope installation

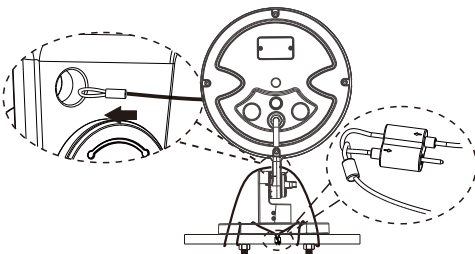

35W

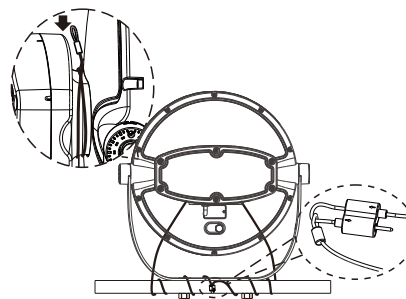

100W/150W



Ansell Electrical Products
 Unit 6B, Stonecross Industrial Park,
 Yew Tree Way,
 Warrington,
 WA3 3JD

Ansell (Sales & Distribution)
 Unit 2, M2 Business Park,
 Duncrue Street,
 Belfast,
 BT3 9AQ

Ansell (Sales & Distribution) Republic of Ireland Limited
 Unit G1, Block G,
 Calmount Park, Calmount Avenue
 Dublin 12,
 D12 TH56

www.anselluk.com

DMX512 Control

Factory default mode for DMX control :

Default address is the same for each luminaire. Take RGBW version for example, there are 4 addresses for each luminaire, that is address 1 for R; 2 for G; 3 for B; 4 for W. When turn on the luminaire, the four colors light up together without flashing if no input signal is detected about 10 seconds later.



35W

100W/150W

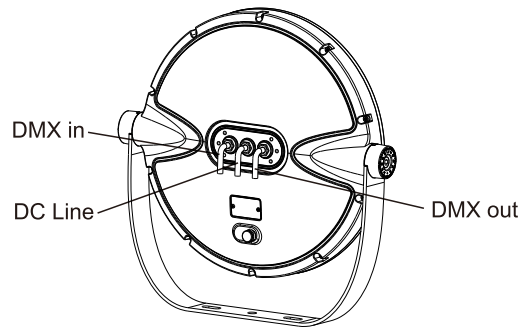
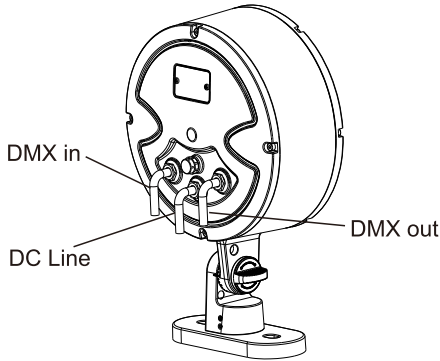

DC Line

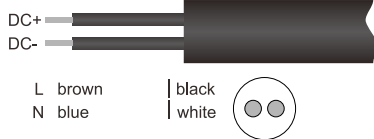

Please connect a signal amplifier every 100 meters or every 32 lights.

35W

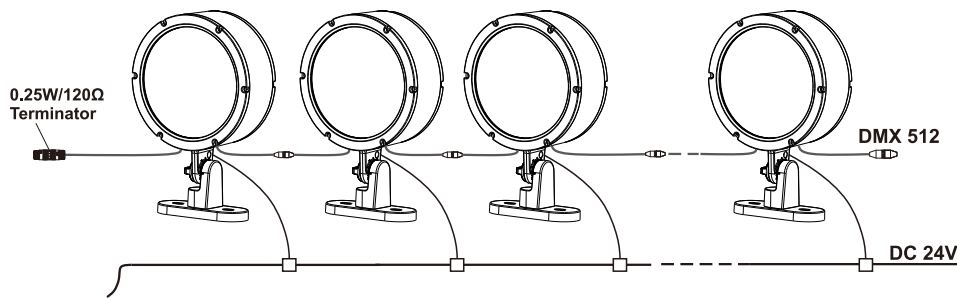

100W/150W

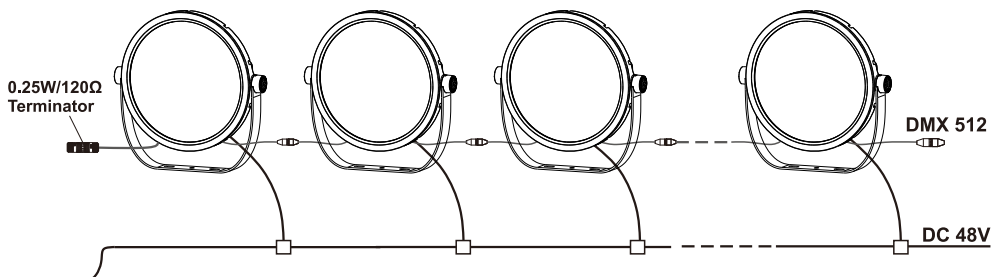

* It is recommended to add 0.25W/120Ω DMX Termination Resistor at the end of each string of luminaires.

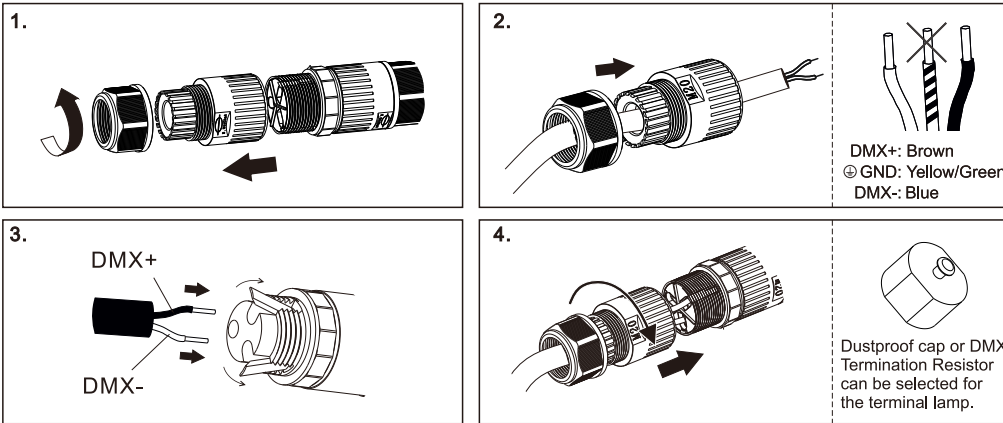

SS-960RDM(Optional)

The DMX controller needs to be purchased separately. We suggest buy our SS-960RDM controller if you need to change the DMX address settings.

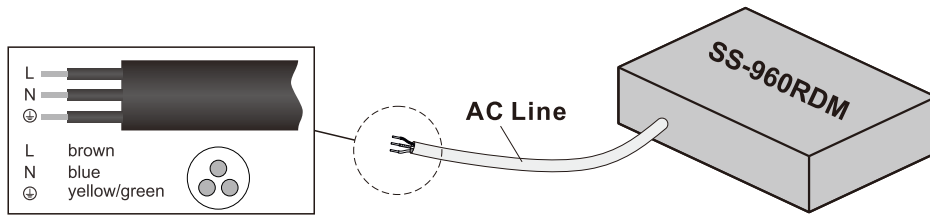

Signal Amplifier(Optional)

It is suggested to connect a signal amplifier every 100 meters or every 32 lights, which can improve the signal stability. If RDM controller is used instead of DMX512 controller, the signal amplifier must be compatible with RDM controller, better to purchase from us directly.

Signal line reversed connection will cause following defects:

1. The luminaire is not controlled.
2. The luminaire keeps flickering.

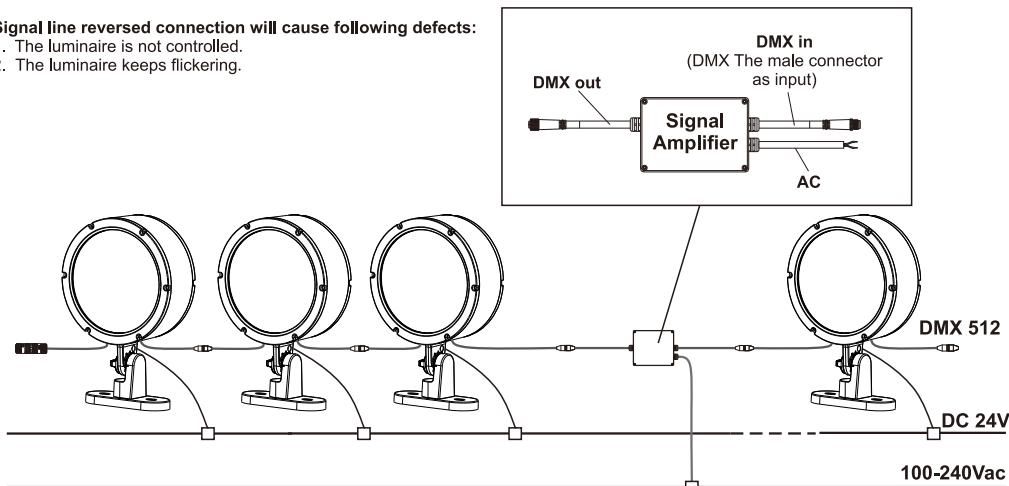

DALI

35W

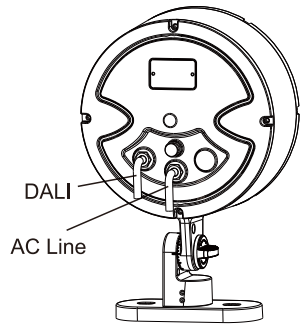

100W/150W

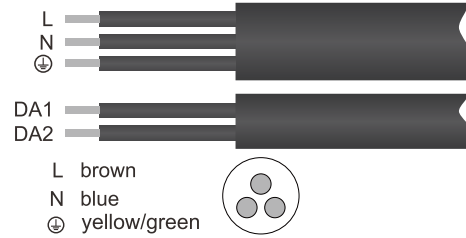
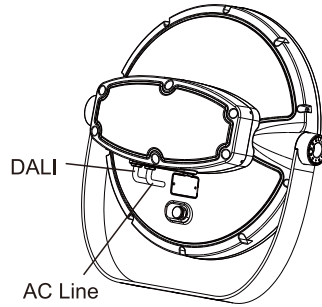

Bluetooth(CASAMBI)

35W

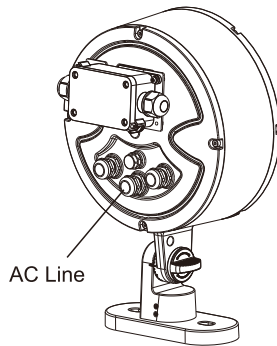

100W

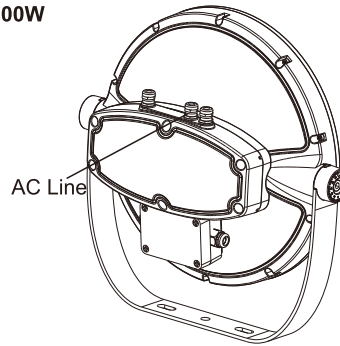

Casambi app operation method

Casambi app is easy to use. Follow these simple steps.

1. Download the app from Apple App Store or Google Play Store.
2. Turn on your Casambi enabled luminaires.
3. Open the app.
4. Casambi app will automatically find all Casambi enabled luminaires that are switched on.
5. Tap on the 'Take all luminaires into use'.
6. Casambi app will automatically add all luminaires to one network and open the 'Luminaires' tab.

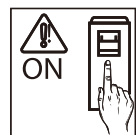
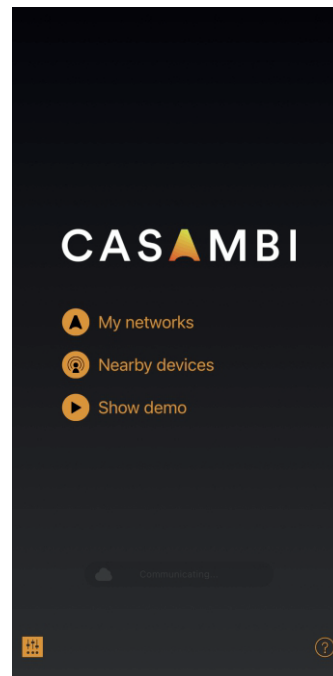

Visor Installation(Optional Accessories)

Visor Dimensions(Unit: mm/inch)

1.

35W

1.

100W/150W

Product Specifications	35W	100W	150W
Input Voltage	100-240VAC / 220-240VAC		
Power Frequency	50 / 60 Hz		
Outlook Dimensions	219.5×330×100mm (8.64"×12.99"×3.94")	450×452×160mm (17.72"×17.79"×6.30")	
Luminaire Net Weight	3.7±0.3kg (8.15±0.66Lbs)	10±0.3kg (22.04±0.66Lbs)	
Projected Area	0.04m ² (0.35ft ²)	0.12m ² (1.12ft ²)	
Working Temperature	-30°C to +50°C(-22°F to +122°F)		
Storing Temperature	-40°C to +70°C(-40°F to +158°F)		

Ansell Electrical Products
Unit 6B, Stonecross Industrial
Park,
Yew Tree Way,
Warrington,
WA3 3JD

Ansell (Sales & Distribution)
Unit 2, M2 Business Park,
Duncrue Street,
Belfast,
BT3 9AQ

Ansell (Sales & Distribution) Republic of Ireland Limited
Unit G1, Block G,
Calmount Park, Calmount Avenue
Dublin 12,
D12 TH56

www.anselluk.com