

Installation Instructions

Instrucciones de instalación, Instructions d'installation, Installationsanleitung, إرشادات التركيب,
 Installatie-instructies, Instruções de instalação, Installatie-instructies,
 設置手順説明, Οδηγίες εγκατάστασης



Product Code:[ANOU /2 - Range]



Master
Translations
QR Link

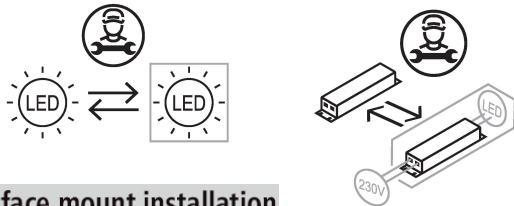
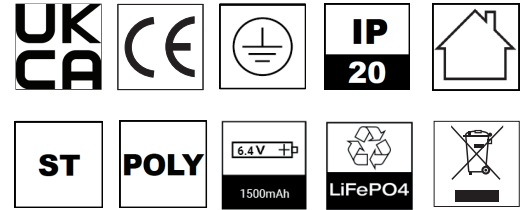

Surface mount installation

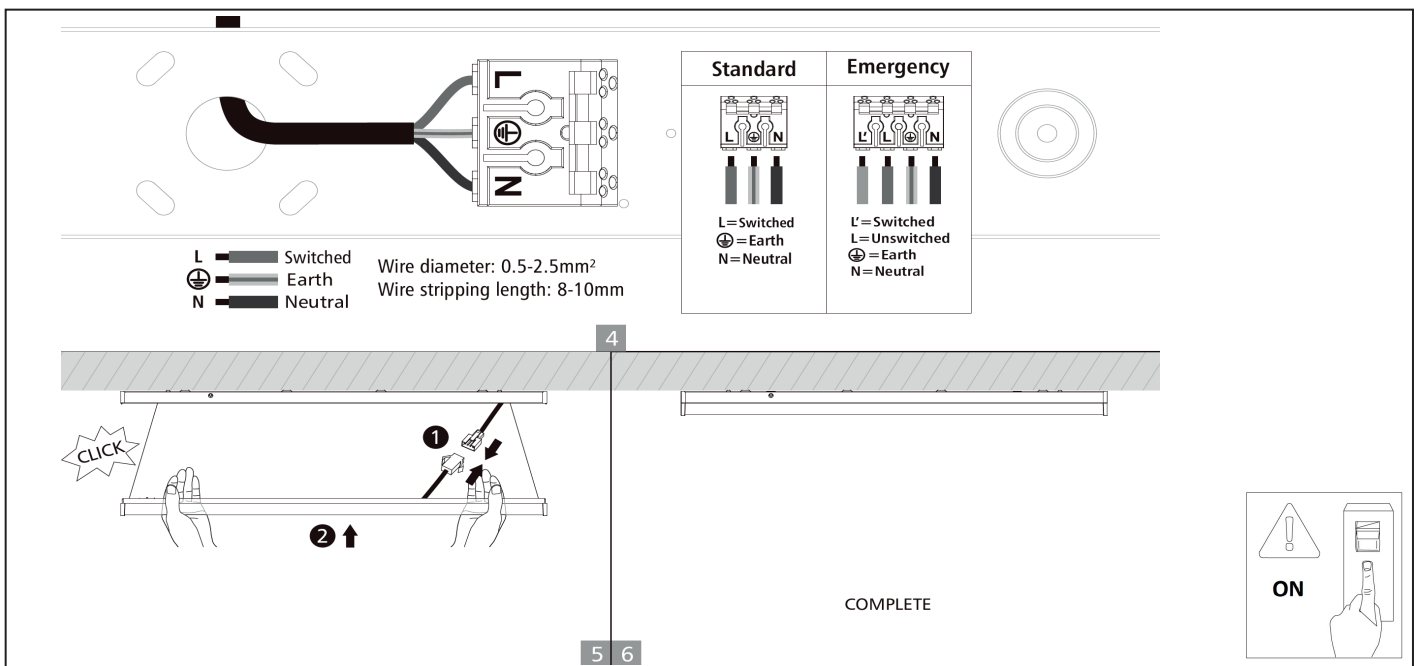
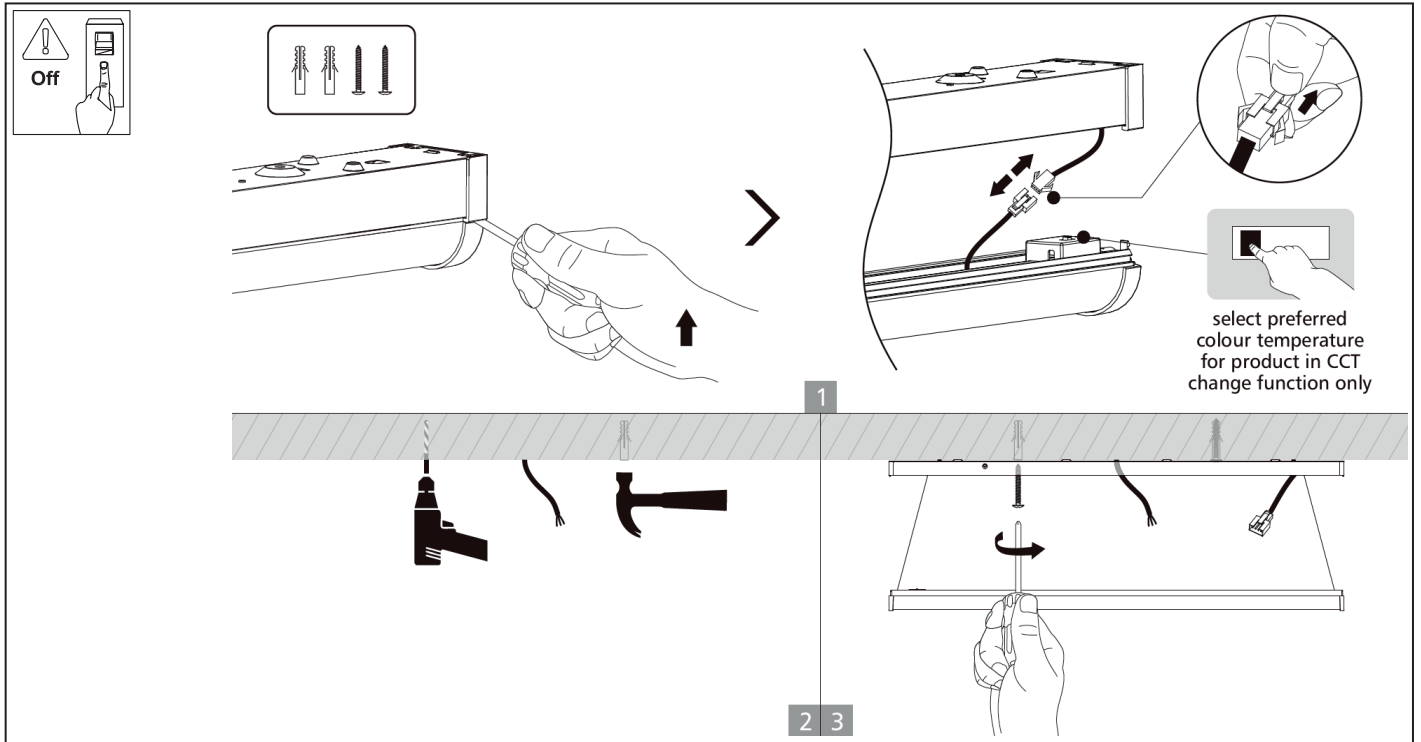

Ansell Electrical Products
 Unit 6B, Stonecross Industrial
 Park,
 Yew Tree Way,
 Warrington,
 WA3 3JD

Ansell (Sales & Distribution)
 Unit 2, M2 Business Park,
 Duncrue Street,
 Belfast,
 BT3 9AQ

Ansell (Sales & Distribution) Republic of Ireland Limited
 Unit G1, Block G,
 Calmount Park, Calmount Avenue
 Dublin 12,
 D12 TH56

www.ansell-lighting.com

Suspended installation

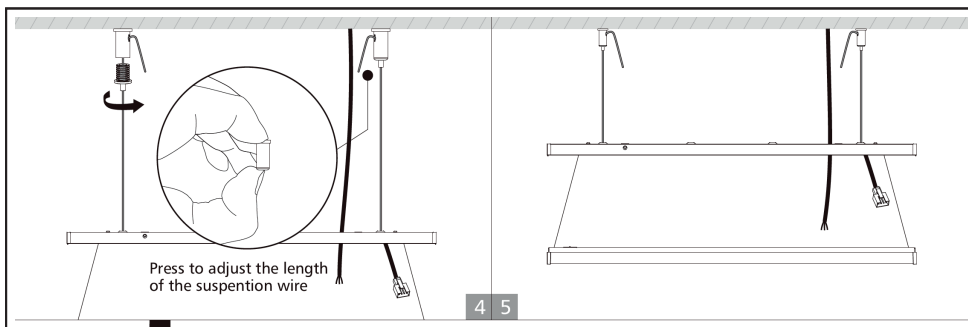
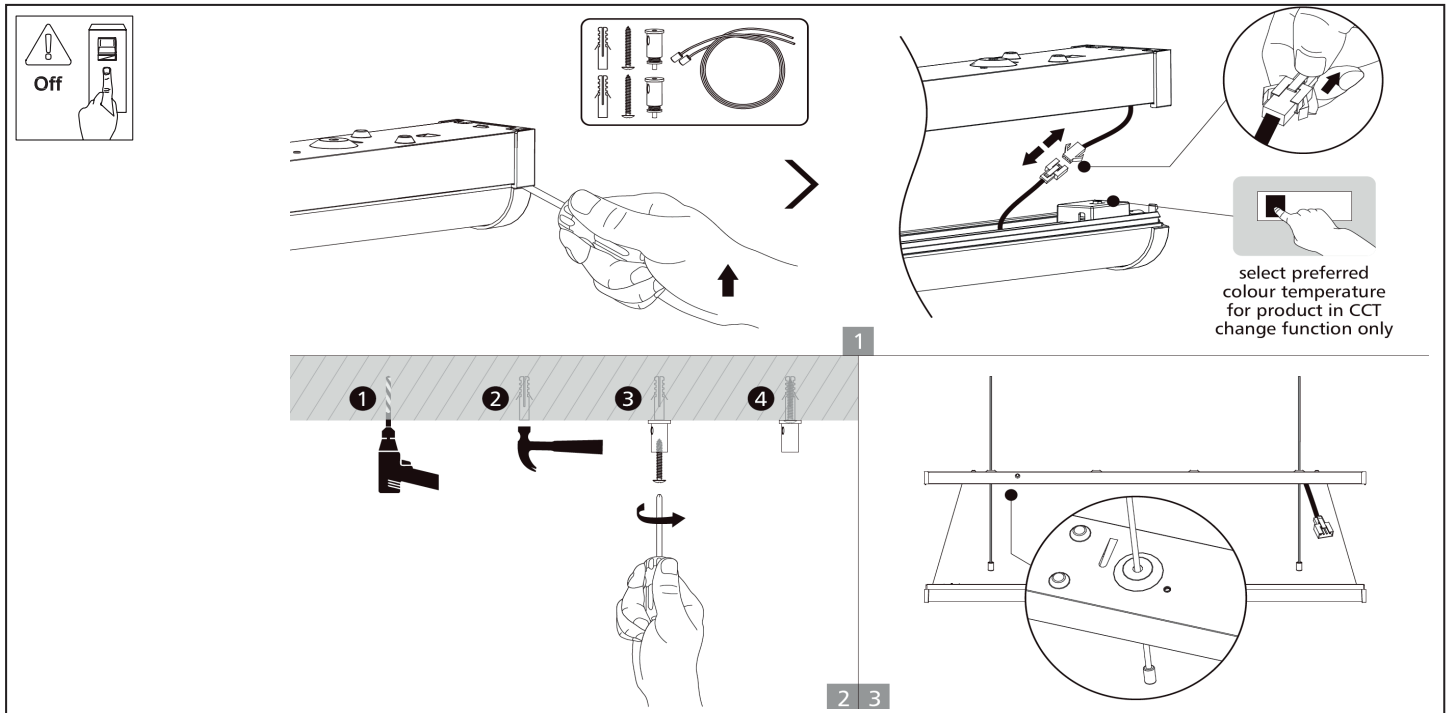

ON ↑

Vout	Po Max	Io	1	2
120-150V	37.5W	250mA	ON	ON
120-150V	20.25W	135mA	-	-

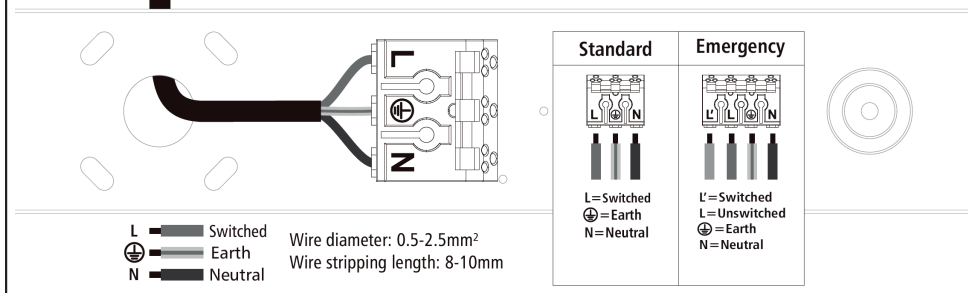

ANO5/2 & ANOU5/2/SM3

Vout	Po Max	Io	1	2
120-150V	50.25W	335mA	ON	ON
120-150V	25.5W	170mA	-	-

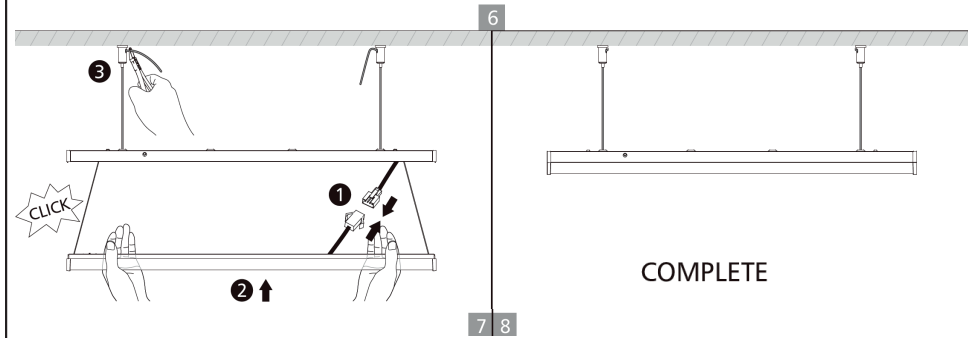

ANO6/2 & ANOU6/2/SM3

Vout	Po Max	Io	1	2
120-150V	50.25W	335mA	ON	ON
120-150V	35.25W	235mA	ON	-

