

Salvus Surface

Installation instructions



collingwood

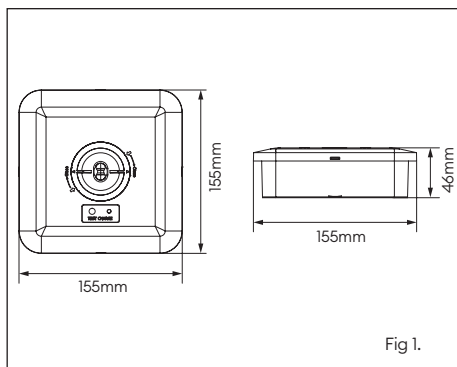

Fig 1.

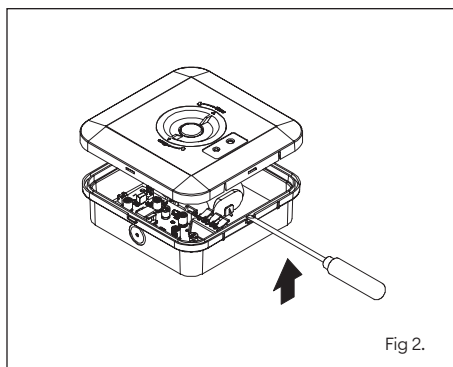

Fig 2.

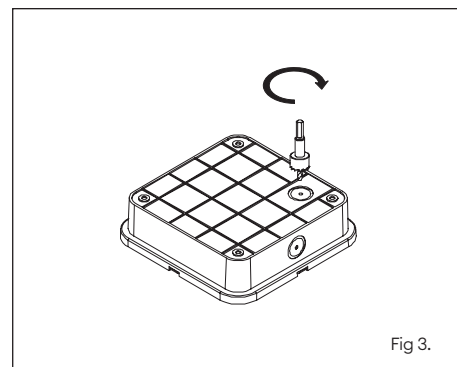

Fig 3.

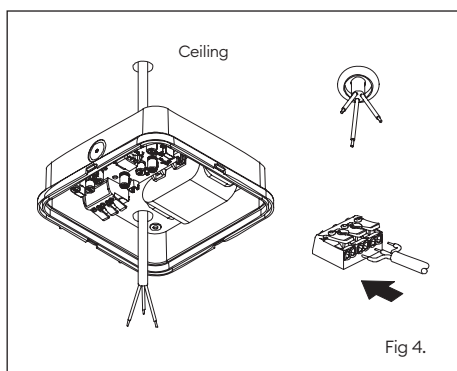

Fig 4.

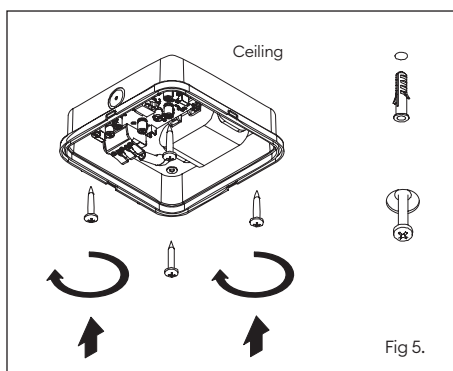

Fig 5.

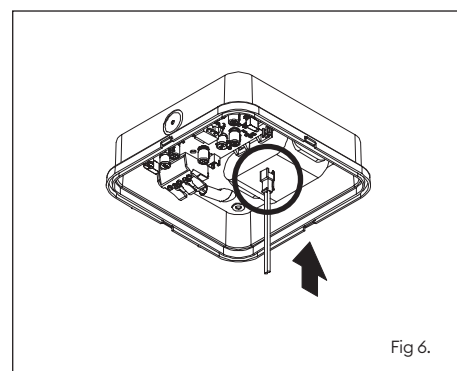

Fig 6.

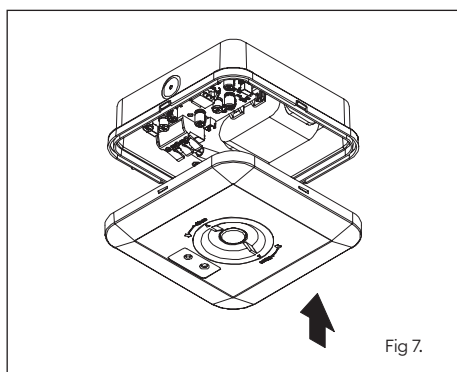

Fig 7.

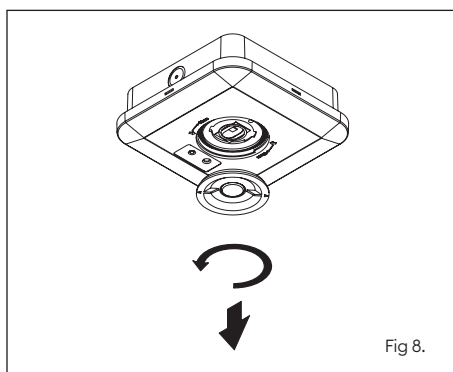

Fig 8.

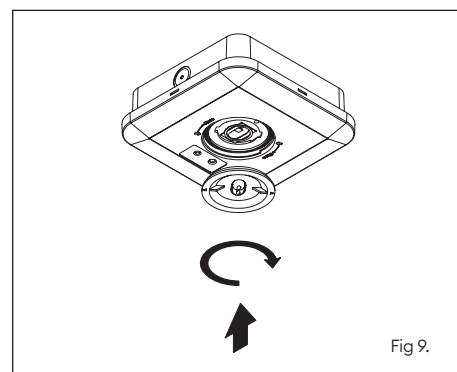
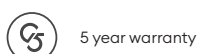

Fig 9.



Disposal of this product should be separate from household waste. Please separate these items from other types of waste and recycle them responsibly to promote the sustainable reuse of material resource. Household users should contact their local government office for details of where and how they can take these items for environmentally safe recycling.

Salvus Surface

Installation instructions



collingwood

en

Installation

1. Important: This unit must be wired by a qualified electrician or suitable competent person. Isolate the mains supply prior to wiring.
2. Establish a mains supply to the light fitting.
3. Open cover front cover by releasing the 4x clips (fig 2).
4. Write the commissioning date on the battery label.
5. Drill out the desired rear or side cable entrance hole.
6. Feed the mains input cable through the cable entrance hole and one of the supplied grommets.
7. Wire the mains cable into the provided terminals, pushing the grommet into the entrance hole when finished.
8. Drill out the 4 mounting holes on the back of the product and also drill the corresponding 4 holes into the mounting surface, fitting the provided wall plugs accordingly.
Drill size (clearance hole) for the supplied screws is: Ø4mm.
Drill size for the supplied wall plugs is: Ø6mm.
9. Screw the back section of the light fitting, onto the mounting surface using the 4x screws provided.
10. Plug the battery cable into the socket on the product (fig 6).
11. Replace the front cover by pressing on to the back section, ensuring all 4 clips are in place.
12. Product comes supplied with corridor (80° x 30°) or open area (150°) lenses. To change the lens, twist the lens anticlockwise and pull away. To install the new lens, push the lens onto the product and twist the lens clockwise.
13. Turn on mains power. The green LED indicator should be lit indicating that the unit is connected correctly and the battery is charging. Battery will be charged after 24 hours. If green LED fails to light, turn off mains power and check battery is connected and product is wired correctly.

Note: Unit is manual test. To test emergency function, mains power must be cut from the product using the master switch for the circuit. See Emergency pack commissioning.

Emergency pack commissioning

1. Provide an uninterrupted mains power supply (permanent live) for 24 hours.
2. Check that the green indicator LED light is lit. This confirms that the battery is charging.
3. Remove the mains supply, the unit will operate under battery power for 3 hours minimum.
4. Restore mains power to the unit, check light functions correctly.

Testing

- Periodic testing of the unit must be performed in line with the appropriate regulations.

Installation data

- The light source of this luminaire is not replaceable. When the light source reaches its end of life the whole luminaire shall be replaced.
- The driver contained in this luminaire shall only be replaced by the manufacturer or service agent or a similar qualified person.
- Battery must be replaced when the unit no longer meet it's rated emergency duration, or if a battery fault occurs.

Rated voltage	220 - 240V AC 50/60Hz
Input current	20mA
Power	1.6W
Power factor	0.4
Inrush current	3.04A
Product weight	380g



5 year warranty



Disposal of this product should be separate from household waste. Please separate these items from other types of waste and recycle them responsibly to promote the sustainable reuse of material resource. Household users should contact their local government office for details of where and how they can take these items for environmentally safe recycling.

Salvus Surface

Installation instructions



collingwood

en

Emergency installation and maintenance record

Product : _____

Installer : _____

Date installed : _____

Commissioning by : _____

Date commissioned : _____

Month	Year 1		Year 2		Year 3		Year 4	
	Signed	Date	Signed	Date	Signed	Date	Signed	Date
1								
2								
3								
4								
5								
6								
7								
8								
9								
10								
11								
12								

 5 year warranty



Disposal of this product should be separate from household waste. Please separate these items from other types of waste and recycle them responsibly to promote the sustainable reuse of material resource. Household users should contact their local government office for details of where and how they can take these items for environmentally safe recycling.