

PS250600MA

Installation instructions

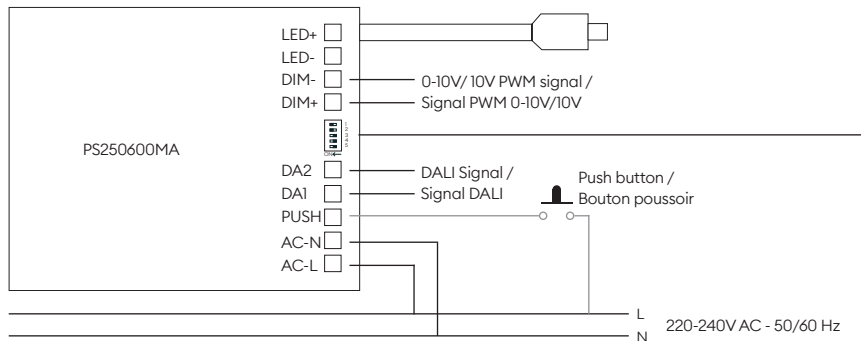

collingwood



DIP switch settings/
Paramètres des commutateurs DIP

Iout DC	1	2	3	4	5
250mA	-	-	-	-	-
300mA	ON/Sur	-	-	-	-
350mA	-	ON/Sur	-	-	-
400mA	ON/Sur	ON/Sur	-	-	-
450mA	-	-	ON/Sur	-	-
500mA	ON/Sur	-	ON/Sur	-	-
550mA	-	ON/Sur	ON/Sur	-	-
600mA	ON/Sur	ON/Sur	ON/Sur	-	-

Installation

- Set the dipswitches to the correct output current.
- Connect the output of the driver (plug and play connector) to the LED unit.
- Connect optional DALI, 0-10V/10V PWM signal or PUSH switch.
- Connect driver to the mains supply.
Note: Corridor function is available by request.

Installation data

- Isolate the mains supply, prior to wiring.
- This unit must be wired by a qualified electrician or suitable competent person.
- For use with 250 - 600mA, 14-42V LED units.
- Do not exceed maximum rated output power of the driver.
- Maximum 20 drivers controlled by one push button.
- Maximum 105m between push button and last driver.

Rated voltage	220 - 240V AC 50/60Hz
Input current	0.18A Max
Power	29W max
Power factor	>0.9
Inrush current	40A 350µs



Disposal of this product should be separate from household waste. Please separate these items from other types of waste and recycle them responsibly to promote the sustainable reuse of material resource. Household users should contact their local government office for details of where and how they can take these items for environmentally safe recycling.



Ce produit ne doit pas être éliminé avec les ordures ménagères. Merci de le séparer des autres déchets et de le recycler de manière responsable afin de promouvoir la réutilisation des ressources matérielles. Les consommateurs doivent contacter leurs autorités locales pour plus d'information quant aux lieux et méthodes de recyclage en accord avec la protection de l'environnement.



5 year warranty
5 ans de garantie