

Safety Information

>All electrical work must be undertaken by a qualified contractor to ensure compliance with latest edition BS7671 and IEE/IET wiring regulations.

> Before installing a LED Sports Light or doing any maintenance, ensure power supply is turned off at the circuit breaker or fuse box.

> This product is designed for permanent connection to fixed wiring; the circuit should be protected with the appropriate MCB or fuse.

>Please DO NOT dispose of electrical items or packaging as unsorted waste. Use the recycling facilities provided by your local authorities.

Non-replaceable light source

>The light source of this luminaire is not replaceable. When the light source reaches its end of life the whole luminaire shall be replaced.

PRODUCT DIMENSIONS

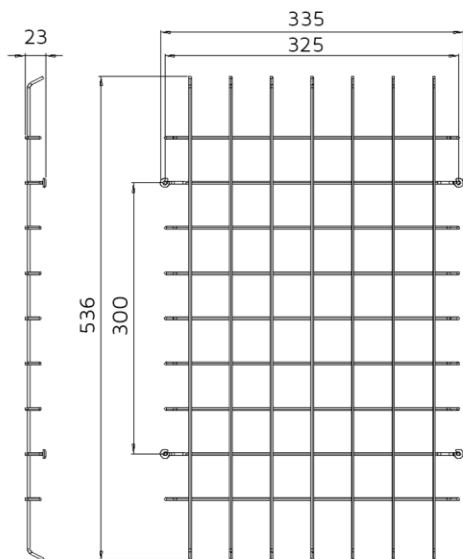

All units are in mm

Important Warranty Information

The LED Sports Light has a 3 year warranty, which can be extended free of charge to 5 years by registering online via the website address below. The registrant must provide the product part number and date of manufacture, which can be found on the label attached to the luminaire housing.



Certificate No. FS 590684



Certificate No. EMS 590685

NET LED Lighting
Buckway Business Park
300 Anderson Road
Cambridge
CB24 4UQ
sales@netled.co.uk
www.netled.co.uk

Technical Helpline: 01223 851505
Email: support@netled.co.uk
www.netled.co.uk/downloads

Distributed by



BENWICK 500W WIRE GUARD

Part Number	Description
NET-23-04-67	Benwick 500W Wire Guard

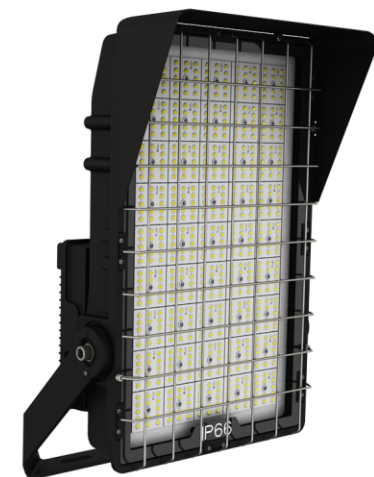
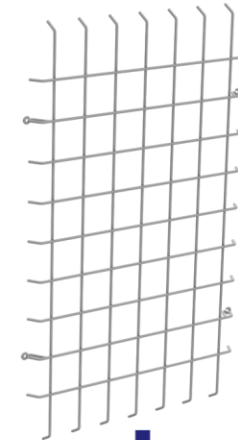

Installation procedure: Carefully read the installation instructions and ensure the mains supply is isolated before installation. Please follow the safety information overleaf before carrying out any installation. Please retain this leaflet for future reference.

Benwick Flood Light Wire Guard Installation:

Step 1: Unpackage the flood light and the wire guard. Ensure that both items are not damaged.

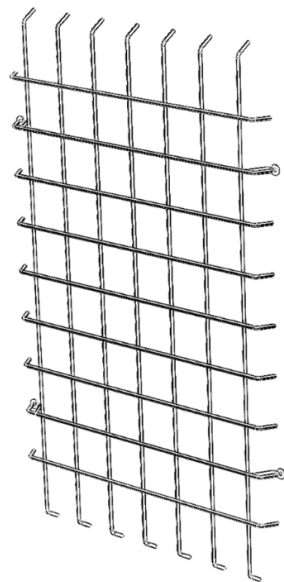

NET-23-04-67
Wire Guard

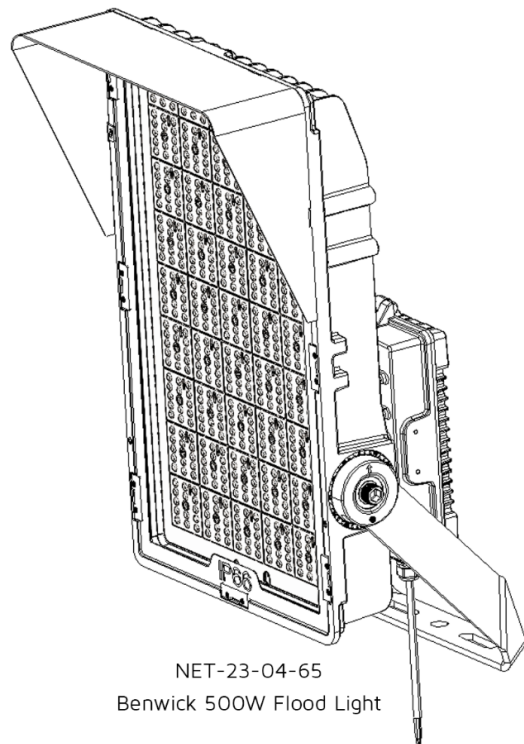

NET-23-04-65
Benwick 500W Flood Light

Step 2: Align the wire guard with the 4x fixing holes on the front face of the Benwick Flood Light. Then insert the 4x fixing screws to secure the wire guard in place. Once the wire guard has been fitted securely, proceed with flood light installation (please refer to the Benwick Flood Light installation guide for instructions).

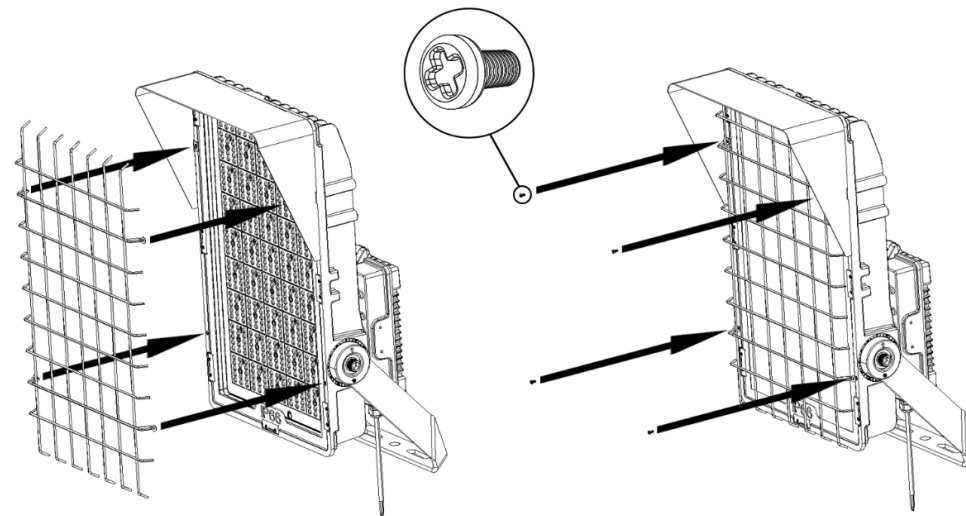

LED High Power Flood Lights

A series of versatile, IP65 rated units for outdoor applications, ranging from 100W to 240W.

5 Year Extended Warranty.



LED Slimline Flood Lights

Available in 20W, 30W, 50W and 100W. The Slimline range is a compact unit compatible with an optional PIR or photocell sensor.



Full product range available

Visit www.netled.co.uk for more commercial LED lighting products, including:

Panel Lights, Downlights, T5 and T8 Tubes, Linear Luminaires, 2D Bulkheads and retrofit Gear Trays, Non-Corrosive Luminaires and much more.