

Safety Information

>All electrical work must be undertaken by a qualified contractor to ensure compliance with latest edition BS7671 and IEE/IET wiring regulations.

> Before installing the Kingston/Hinxton LED Panel or doing any maintenance, ensure power supply is turned off at the circuit breaker or fuse box.

> This product is designed for permanent connection to fixed wiring; the circuit should be protected with the appropriate MCB or fuse.

Environment

>Please DO NOT dispose of electrical items or packaging as unsorted waste. Use the recycling facilities provided by your local authorities.



PRODUCT DIMENSIONS

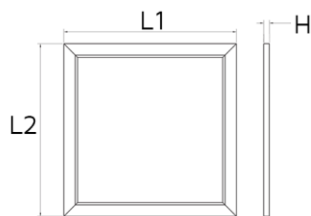

	Size	L1	L2	H
Kingston	295x295	295	295	10
	595x295	595	295	
	495x495	495	495	
	595x595	595	595	
	1195x295	1195	295	
	1195x595	1195	595	
Hinxton	595x595	595	595	9
	1195x595	1195	595	

All units are in mm

Important Warranty Information

The Kingston/Hinxton LED Panel Light has a 3 year warranty, which can be extended free of charge to 5 years by registering online via the website address below. The registrant must provide the product part number and date of manufacture, which can be found on the label attached to the luminaire housing.

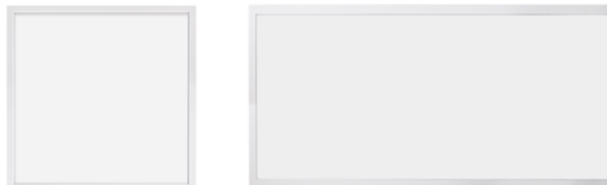

Certificate No. FS 590684



Certificate No. EMS 590685

NET LED Lighting
Buckingham Business Park
300 Anderson Road
Cambridge
CB24 4UQ
sales@netled.co.uk
www.netled.co.uk

Technical Helpline: 01223 851505
Email: support@netled.co.uk

www.netled.co.uk/downloads

Distributed by



LED PANEL INSTALLATION GUIDE

KINGSTON RANGE



Part Number	Description
NET-39-03-00	300x300mm Standard
NET-39-03-32	300x300mm Emergency
NET-39-03-01	600x300mm Standard
NET-39-03-33	600x300mm Emergency
NET-39-03-02	500x500mm Standard
NET-39-03-03	500x500mm Emergency
NET-39-03-05	500x500mm Dimmable
NET-39-03-07	500x500mm Dimmable Emergency
NET-39-03-04	600x600mm Standard
NET-39-03-09	600x600mm Emergency
NET-39-03-10	600x600mm Dimmable
NET-39-03-11	600x600mm Dimmable Emergency
NET-39-03-06	1200x300mm Standard
NET-39-03-12	1200x300mm Emergency
NET-39-03-13	1200x300mm Dimmable
NET-39-03-14	1200x300mm Dimmable Emergency
NET-39-03-08	1200x600mm Standard
NET-39-03-15	1200x600mm Emergency
NET-39-03-16	1200x600mm Dimmable
NET-39-03-17	1200x600mm Dimmable Emergency
NET-39-03-30	600x600mm Tunable White Standard
NET-39-03-31	600x600mm Tunable White Emergency

HINXTON RANGE

Part Number	Description
NET-39-03-24	600x600mm Standard
NET-39-03-18	600x600mm Emergency
NET-39-03-19	600x600mm Dimmable
NET-39-03-20	600x600mm Dimmable Emergency
NET-39-03-28	1200x600mm Standard
NET-39-03-21	1200x600mm Emergency
NET-39-03-22	1200x600mm Dimmable
NET-39-03-23	1200x600mm Dimmable Emergency

Installation procedure: Carefully read the installation instructions and ensure the mains supply is isolated before installation. Please follow the safety information overleaf before carrying out any installation. Please retain the leaflet for future reference. Important: When installing, leave a space of at least 1.2m between the LED Panel and any heating source/air conditioning unit.

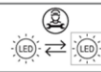
LED Panel Installation:

 Replaceable (LED only) light source by a professional
  Replaceable control gear by professional

Step 1: Carefully remove the LED Panel and driver from the packaging. Remove the ceiling tile from the location where you want to install the LED Panel.

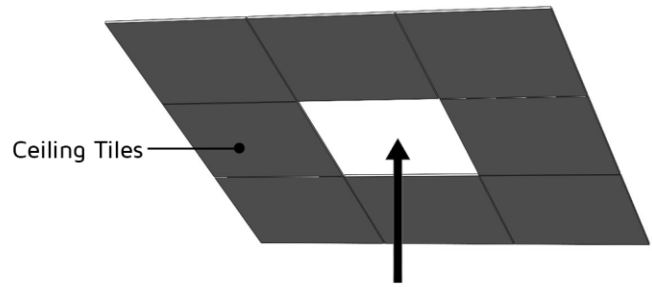

Fig.1

Step 2: Wire the flying leads from the LED Driver into the mains supply, Fig.2.

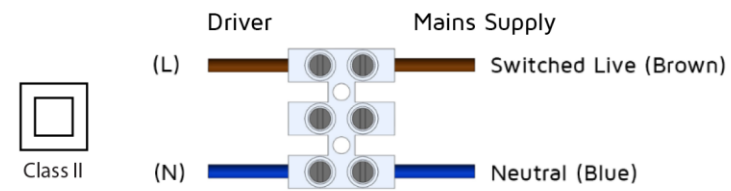

Fig.2

Step 3: Connect the panel light and driver, Fig.3.

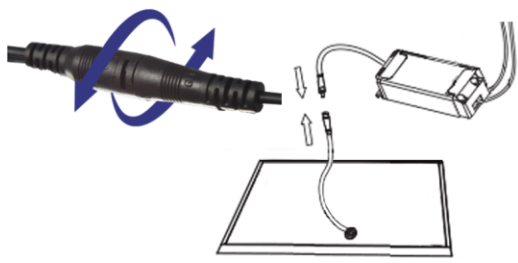

Fig.3

Step 4: Move the LED Panel into the ceiling aperture and ensure the LED Panel is mounted securely, Fig.4a. Finally, turn on the mains supply to check the panel is working correctly, Fig.4b.

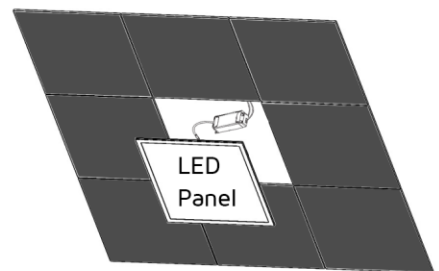

Fig.4a

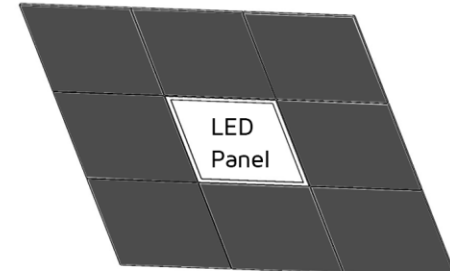
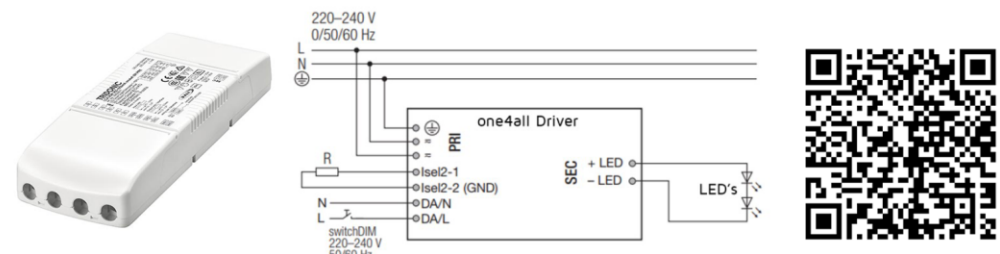

Fig.4b

Alternate wiring diagrams

Dimmable LED Panel wiring diagram:



For more Dimmable and Dimmable Emergency information, please refer to the above QR code for driver wiring instructions.

Emergency wiring diagram:

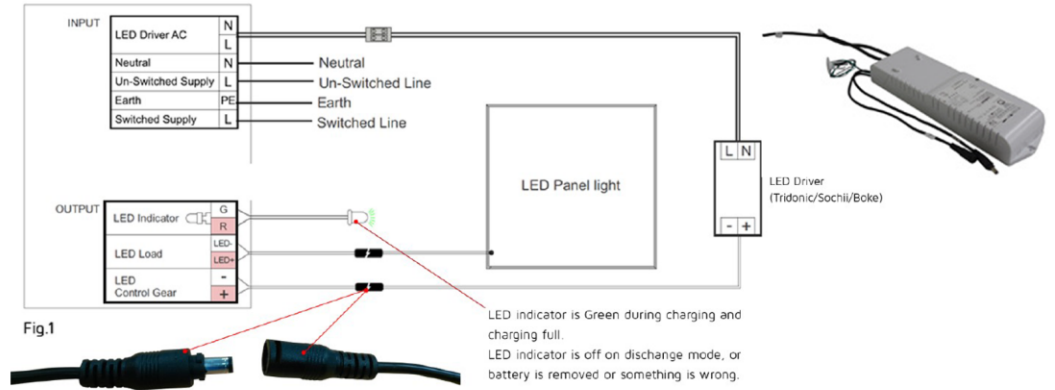

Fig.1

Wiring to the plug-in power terminal:

- Use solid wire or stranded wire with the correct cross-section
- Strip off correct length of insulation; you may need to twist the tool slightly
- If stranded wire is used: push onto the terminal from above to be able to insert the wire
- Insert the bare end into the terminal

Mains supply wires

Stranded with or solid wire from 0.5 to 2.5mm² may be used for wiring.

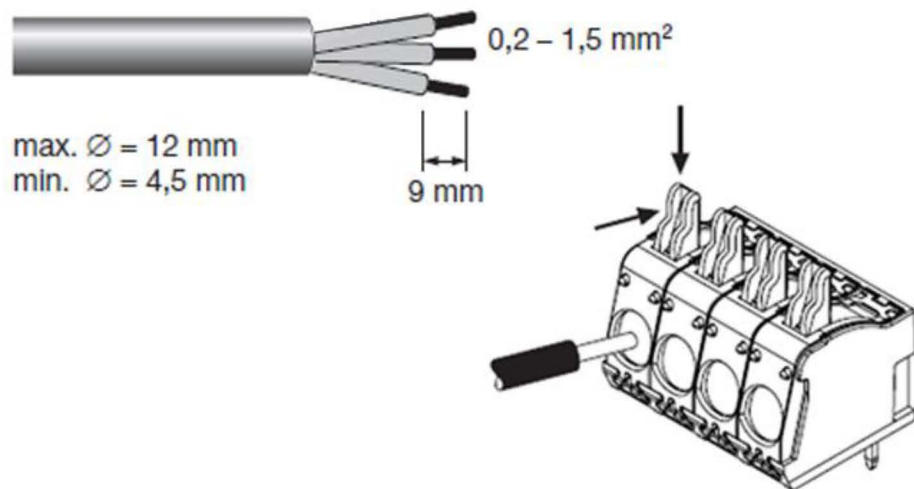

For more information regarding driver settings/options, please access the QR code below:



Website

<http://www.tridonic.com/28002584>

TRIDONIC

Tunable Driver Installation Guide

Distributed by



Certificate No. FS 590684



Certificate No. EMS 590685

NET LED Lighting
Buckingway Business Park
300 Anderson Road
Cambridge
CB24 4UQ
sales@netled.co.uk
www.netled.co.uk

Technical Helpline: 01223 851505
Email: support@netled.co.uk

www.netled.co.uk/downloads

Installation procedure: Carefully read the installation instructions and ensure the mains supply is isolated before installation. Please follow the safety information overleaf before carrying out any installation. Please retain this leaflet for future reference.

Product description:

- Independent dimmable constant current 2-channel LED Driver with strain-relief
- Forms automatically a wireless communication network with up to 250 nodes
- Dimming range 1-100%
- Suitable for luminaires of protection class I and protection class II
- Max. output power 38W
- Up to 87% efficiency
- Power input on stand-by <0.37 W
- Nominal lifetime up to 100,000 h

Interfaces:

- basicDIM Wireless
- Terminal blocks: 45° / 0° push terminals

Functions:

- Constant light output function (CLO)
- Power-up fading and fade2zero
- Protective features (over temperature, short-circuit, overload, no-load, reduced surge amplification)
- Tunable white application

Network compatibility:

- This Driver is fully compatible with networks which support up to 250 nodes (Evolution networks). If the Driver is used with different types of basicDIM Wireless devices in an Evolution network, their compatibility has to be checked before. If a device is not compatible the Evolution networks, it can be only used in networks which support up to max. of 127 devices (Classic networks).

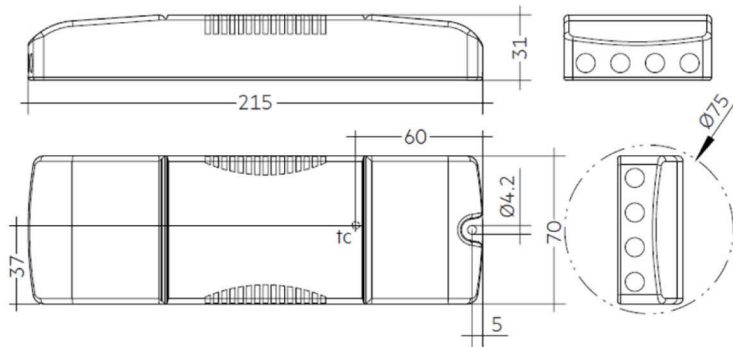

Additional technical information at www.tridonic.com (Technical Data)

Configuration:

To configure the driver, download the **4remote BT App**

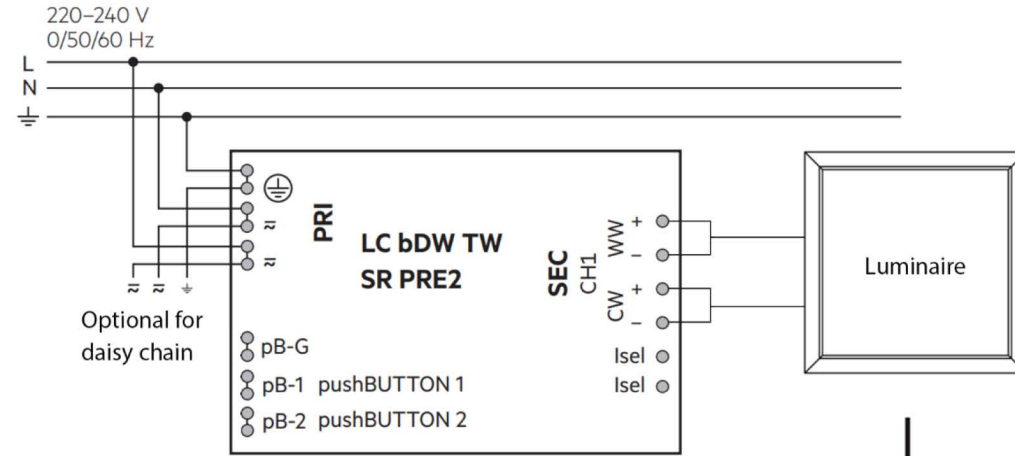

Press down the 'push button' and remove the cable from front.

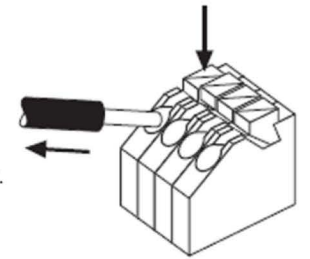

Replaceable (LED only) light source by a professional



Replaceable control gear by professional

Test types: C = Commissioning and verification test
 M = Monthly test (see BS EN 50172) short function test
 A = Annual test (BS EN 50172) full rated duration test

Date of test	Test Type	Result - Test passed No action needed	Result - Test failed	
		Name	Need for repair of system notified Name	Need for safeguarding of premises notified Name
	C			
	M - 1st Month			
	M - 2nd Month			
	M - 3rd Month			
	M - 4th Month			
	M - 5th Month			
	M - 6th Month			
	M - 7th Month			
	M - 8th Month			
	M - 9th Month			
	M - 10th Month			
	M - 11th Month			
	A - ___ Year			
	M - 1st Month			
	M - 2nd Month			
	M - 3rd Month			
	M - 4th Month			
	M - 5th Month			
	M - 6th Month			
	M - 7th Month			
	M - 8th Month			
	M - 9th Month			
	M - 10th Month			
	M - 11th Month			
	A - ___ Year			
	M - 1st Month			
	M - 2nd Month			
	M - 3rd Month			
	M - 4th Month			
	M - 5th Month			
	M - 6th Month			
	M - 7th Month			
	M - 8th Month			
	M - 9th Month			
	M - 10th Month			
	M - 11th Month			
	A - ___ Year			



NET-50-33-02



Installation and Operating Instructions for STREAMER Emergency Lighting Kit (Tunable Panels)

NET LED Ltd.
 Buckingham Business Park
 300 Anderson Road
 Cambridge
 CB24 4UQ
 sales@netled.co.uk
 www.netled.co.uk

Technical Helpline: 01223 851505
 Email: support@netled.co.uk



Important Warranty Information

The Emergency Lighting Kit has a 3 year warranty. To claim you must provide the product part number and date of manufacture, which can be found on the label attached to the luminaire housing along with the original purchase invoice.

Installation procedure: Carefully read the installation instructions and ensure the mains supply is isolated before installation. Please follow the safety information overleaf before carrying out any installation. Please retain this leaflet for future reference.

Step 1: Wiring Connection Details

Remove the Emergency Kit from the packaging.

Connect the Emergency Kit to the LED Panel following the wiring guide. Fig.1 shows the typical wiring of the Emergency kit.

The Emergency Kit must have a connection to an unswitched supply originating from the same supply as the mains lighting in the area in which it is to be installed.

When wiring is complete, ensure the cables are secured in place using the fixings supplied.

LED indicator is Green during charging and charging full.
LED indicator is off on discharge mode, or battery is removed or something is wrong.

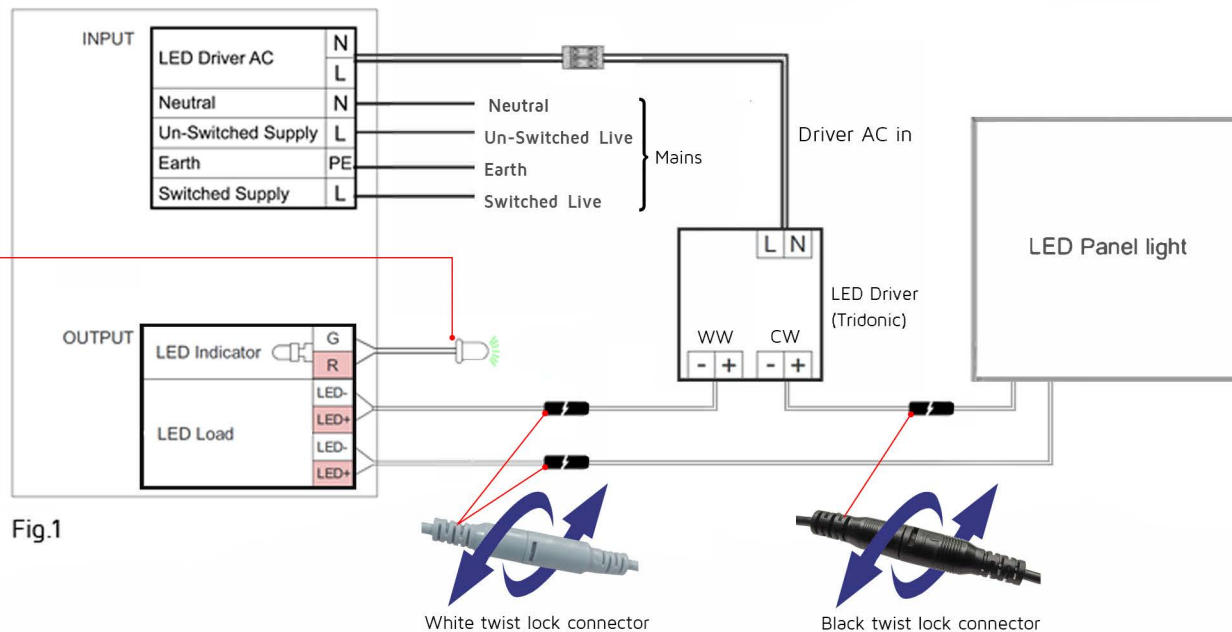

Fig.1

White twist lock connector

Black twist lock connector

Tunable panel colour temperature can be customised by downloading the 4remote BT app.

TRIDONIC

Website

<http://www.tridonic.com/28002584>



Step 2: Apply Mains Supply

Apply mains supply to test the LED tube. The indicator LED will show green.

NOTE: The indicator LED must be visible when the fitting is in normal use, in accordance with BS EN 60598-2-22.

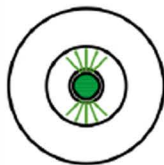

Step 3: Test Emergency Supply

To test, briefly fail the unswitched and mains supply to illuminate fitting from the internal battery. The indicator LED will be extinguished and the LEDs on the Tube will illuminate.

NOTE: If the battery has not been charged for an extended period, the luminaire may only illuminate briefly or fail to operate until the battery is charged.

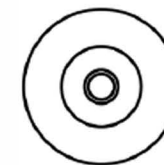

General Description

- Luminaire should only be installed by suitably qualified personnel.
- Installation should be carried out in accordance with the requirements of BS7671 and luminaires located as required by BS5266 Pt. 1 as well as BS EN 1838 and BS EN 50172.
- Before installing, connecting or servicing these luminaires, isolate the mains supply to which they are to be connected.
- To comply with the requirements of BS EN 50172 it is necessary to record the indicator LED status.

Technical Specifications	
Power	4.5W
Input Voltage AC	220-240V
Power Factor	>0.5
Output Voltage	DC 10-50V
Output Power	3W
Battery Pack	LiFePO4 6.4V 2200Ah
Battery Cut-off	5V
Recharge Period	16H
Hours Maintained	>3H
Operating Temperature	0°C to +50°C
Weight	0.38Kg

Emergency Kit Dimensions

