

KOBLE

www.koblesigns.com

Axel Smart Desk Assembly Instructions

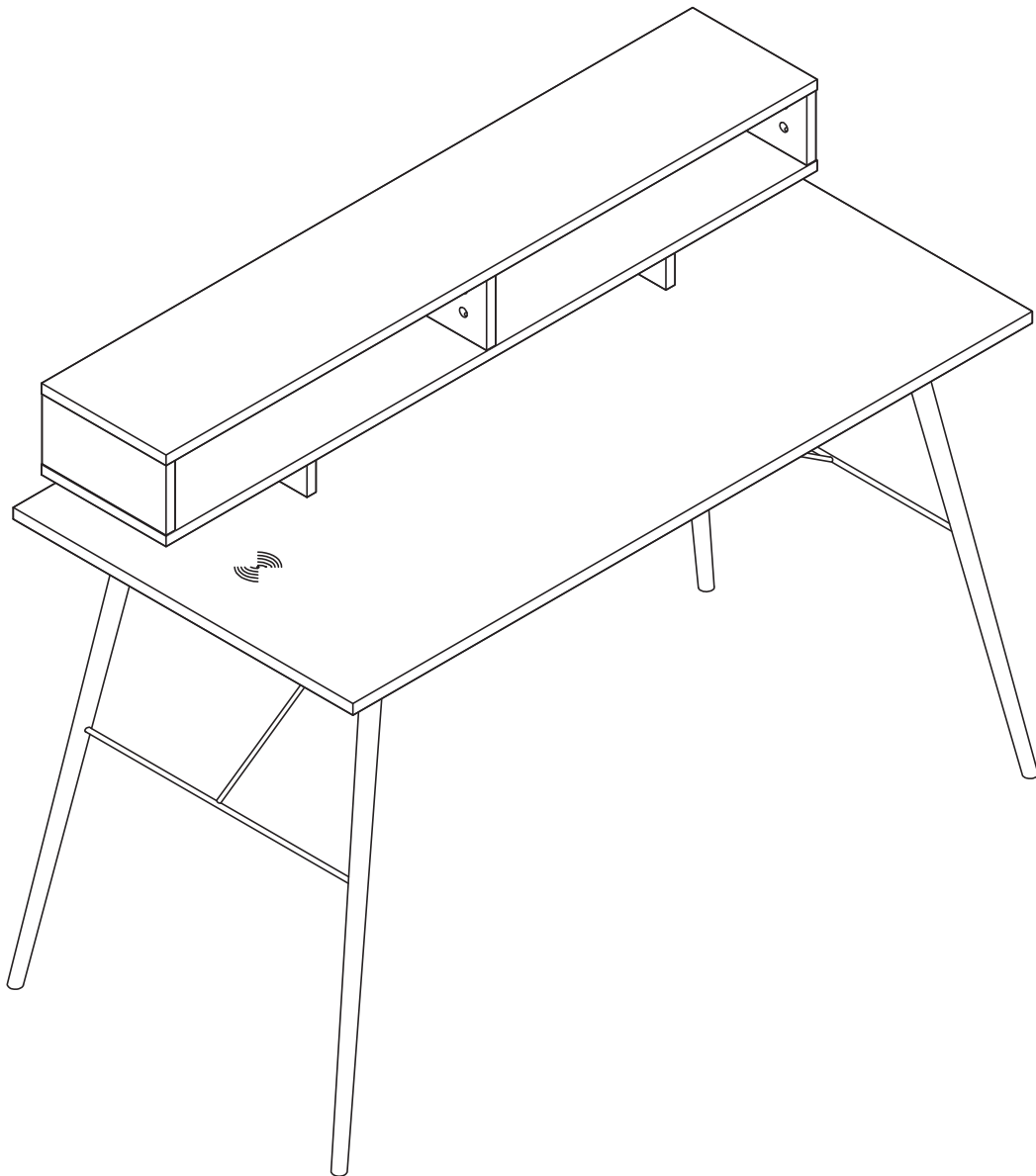

Thank you for purchasing the Axel Desk. In order to make the best use of this product and to use it safely, please read the manual carefully before use and Thank you for keep it for future reference.

STOCK REF. :DOAXEL

Imported By: Koble Designs(Justwise Group Ltd). CB11 3AP.

Main Components

Please check you have all the parts listed below

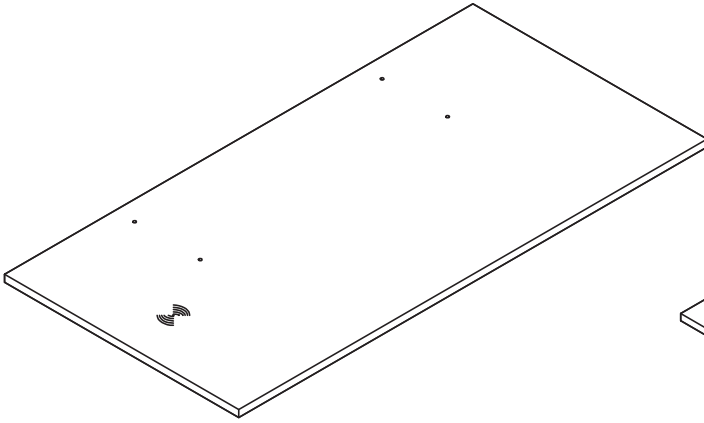

1 Top Qty 1
(1200x600x18mm)

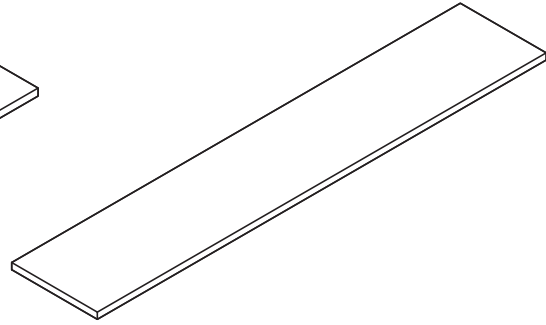

2 Shelf Top Panel Qty 1
(1150x220x16mm)

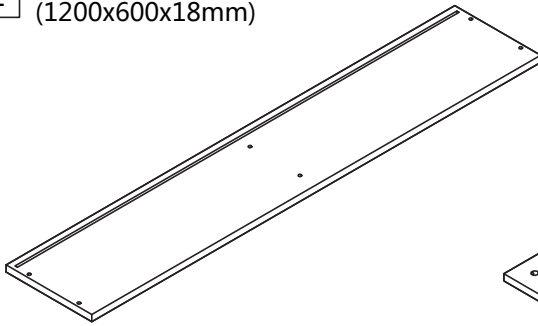

3 Shelf Base Panel Qty 1
(1150x220x16mm)

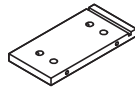

4 Shelf Side Panel Qty 2
(108x219x16mm)

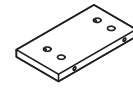

5 Divider Qty 1
(108x199x16mm)

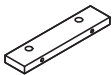

6 Shelf Support Qty 2
(50x219x18mm)

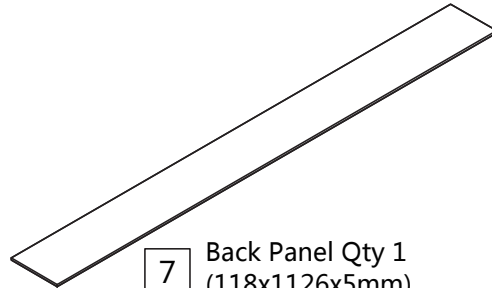

7 Back Panel Qty 1
(118x1126x5mm)

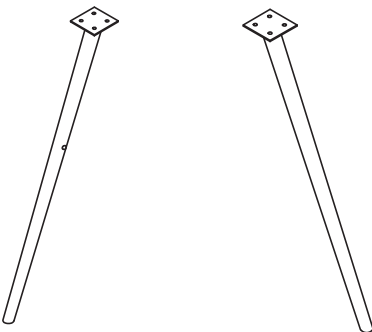

8 Leg (Left) Qty 2
(732mm)

9 Leg (Right) Qty 2
(732mm)

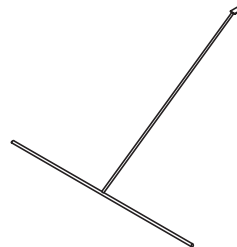

10 Metal Support Qty 2
(490x580mm)

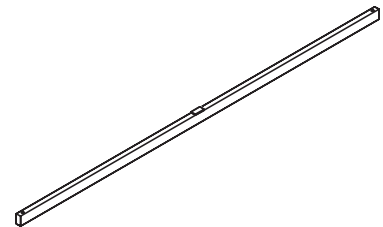







11 Stretcher Qty 2
(940mm)

For missing or damaged parts, call our Customer Helpline: 01799 513466 or email cs@kobledesigns.com

Fixings, Fittings And Tools

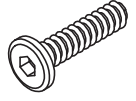
Please check you have all the parts listed below

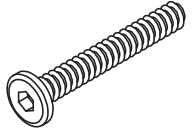
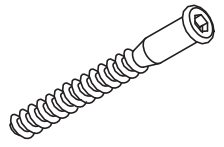
Note: The quantities below are the correct amount to complete the assembly. In some cases more fittings may be supplied than are required.

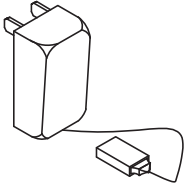
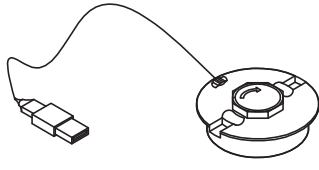
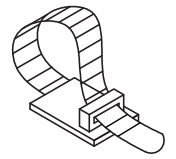
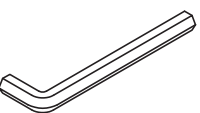
<p>A</p>  <p>M6*40 Cam Dowel Qty 16</p>	<p>B</p>  <p>Φ15*12 Cam nut Qty 16</p>	<p>C</p>  <p>Self adhesive covers Qty 16</p>	<p>D</p>  <p>M6*16 Allen Screw Qty 14</p>
<p>E</p>  <p>M6 Split Lock Washer Qty 14</p>	<p>F</p>  <p>M6 Washer Qty 14</p>	<p>G</p>  <p>M6*45 Allen Screw Qty 4</p>	<p>H</p>  <p>Screw Qty 4</p>
<p>J</p>  <p>Corner bracket Qty 6</p>	<p>K</p>  <p>Power Adapter 150cm Qty 1</p>	<p>L</p>  <p>Wireless Charging Coil Qty 1</p>	<p>M</p>  <p>Cable Clips Qty 3</p>
<p>N</p>  <p>M4 Allen Key Qty 1</p>			

Tools needed (Not supplied)

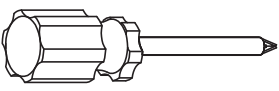
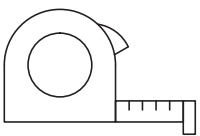
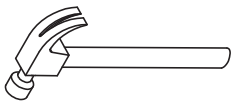
 <p>Screwdriver</p>	 <p>Tape Measure</p>	 <p>Hammer</p>
---	---	--

For missing or damaged parts, call our Customer Helpline: 01799 513466 or email cs@kobledesigns.com

Main Component Diagram

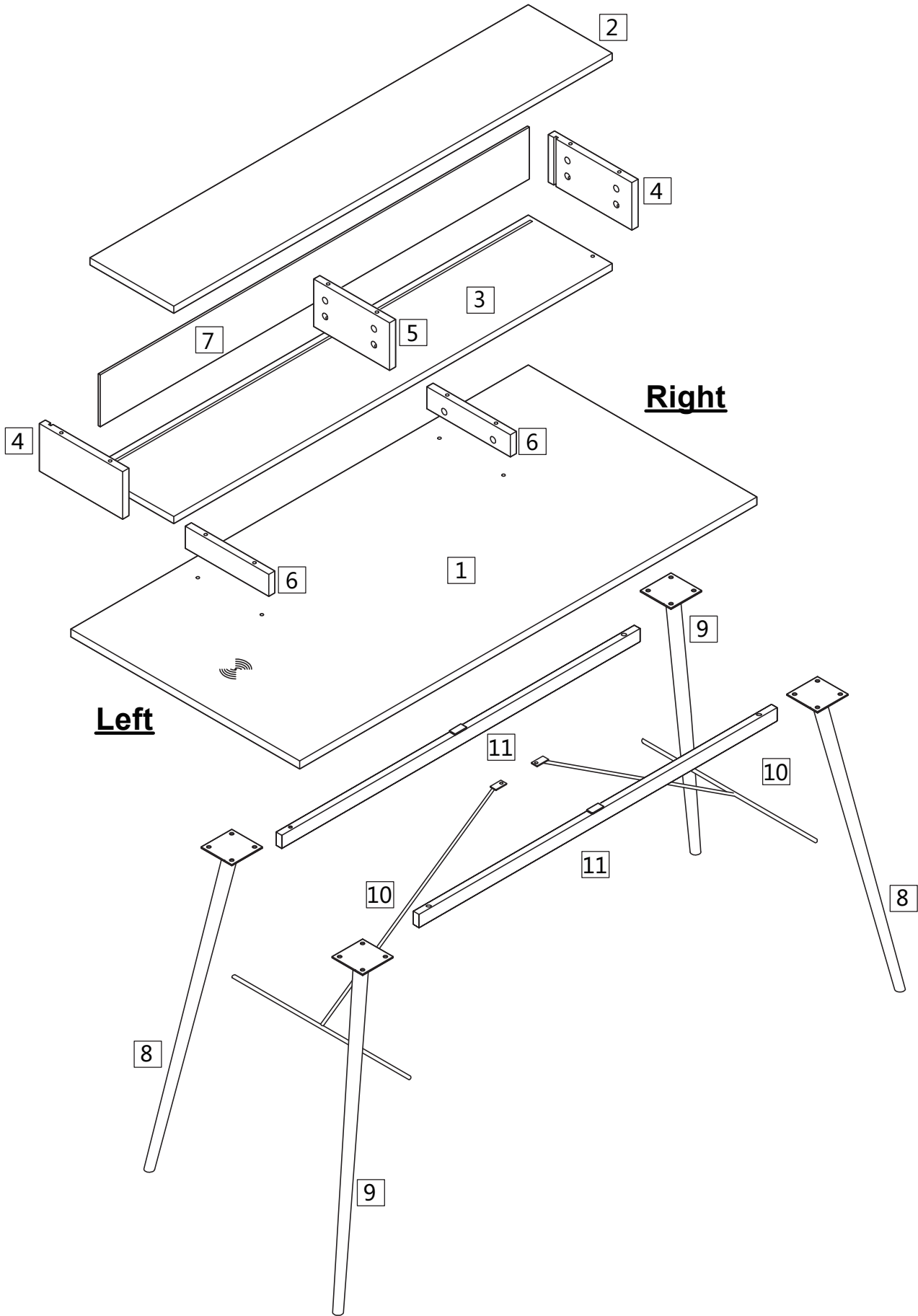

For missing or damaged parts, call our Customer Helpline: 01799 513466 or email cs@kobledesigns.com

Assembly Steps

Step 1

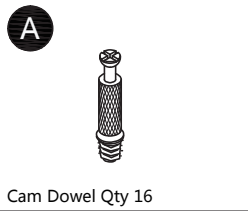
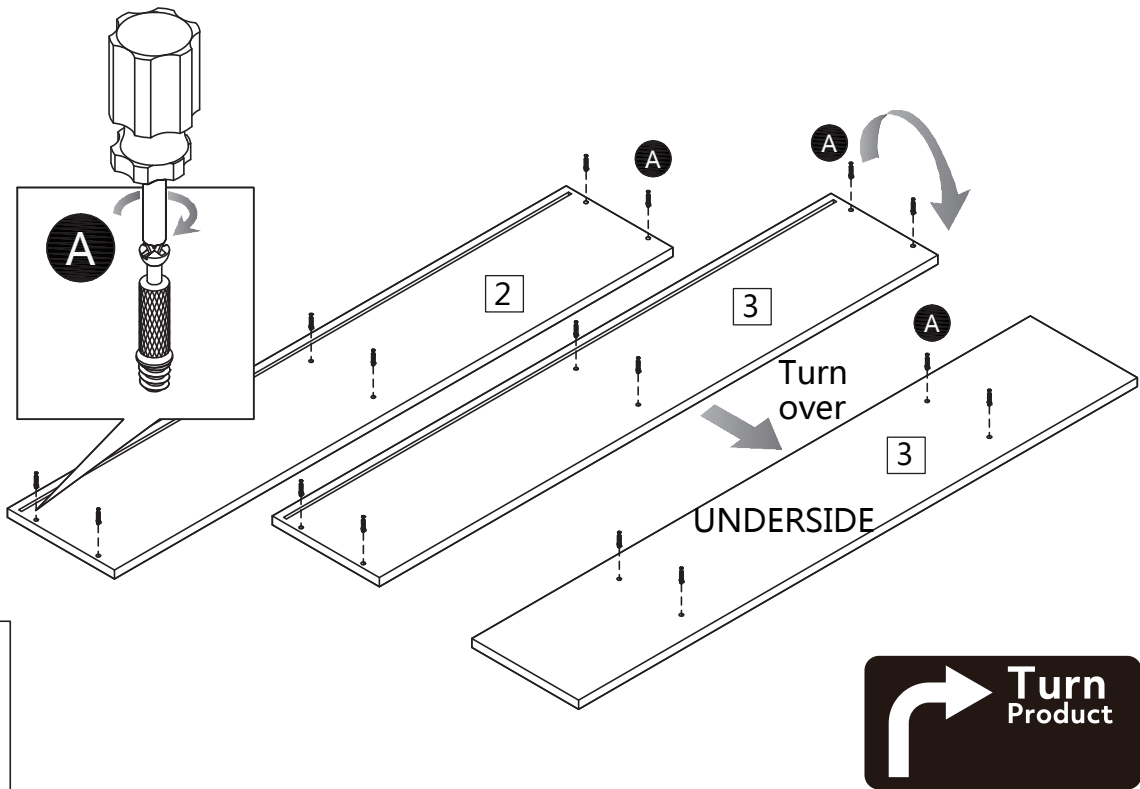

Step 2

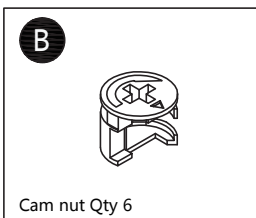
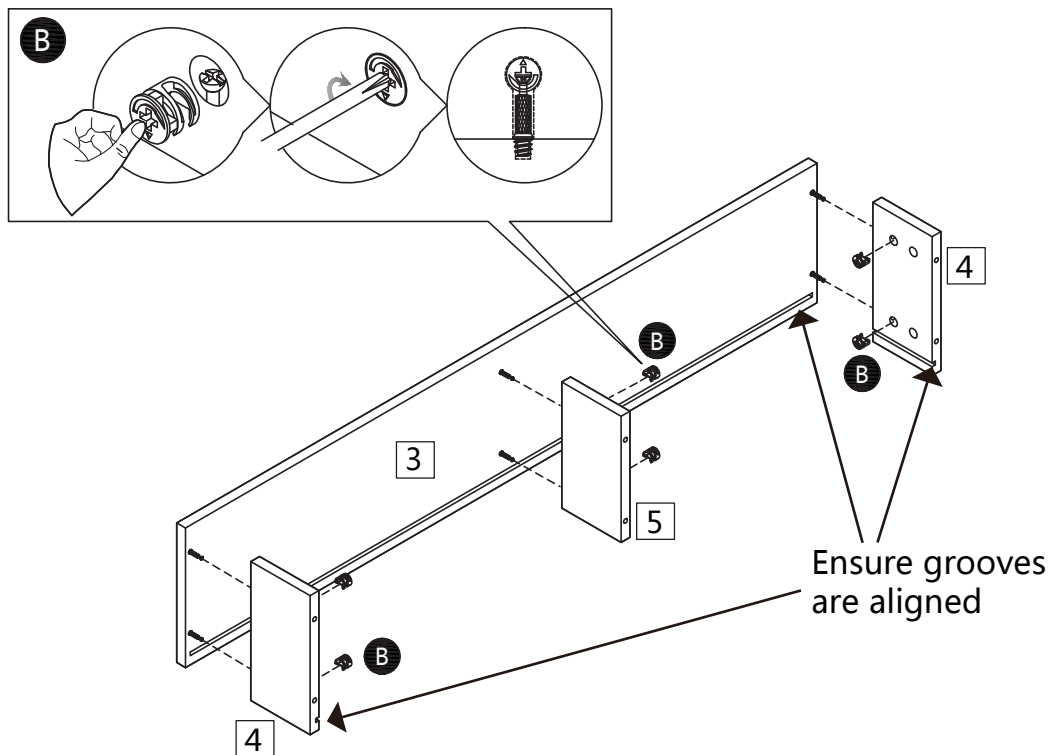

Assembly Steps

Step 3

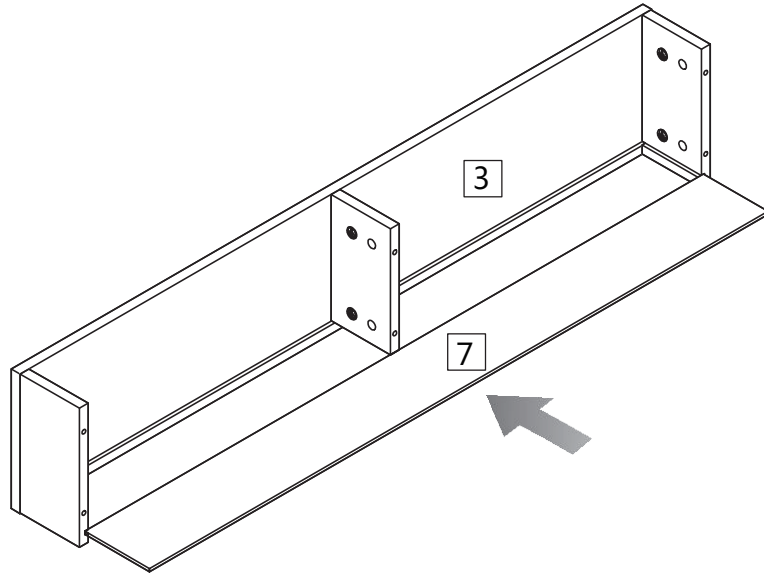

Step 4

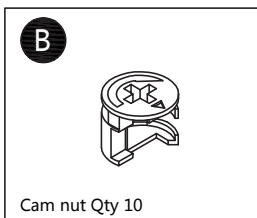
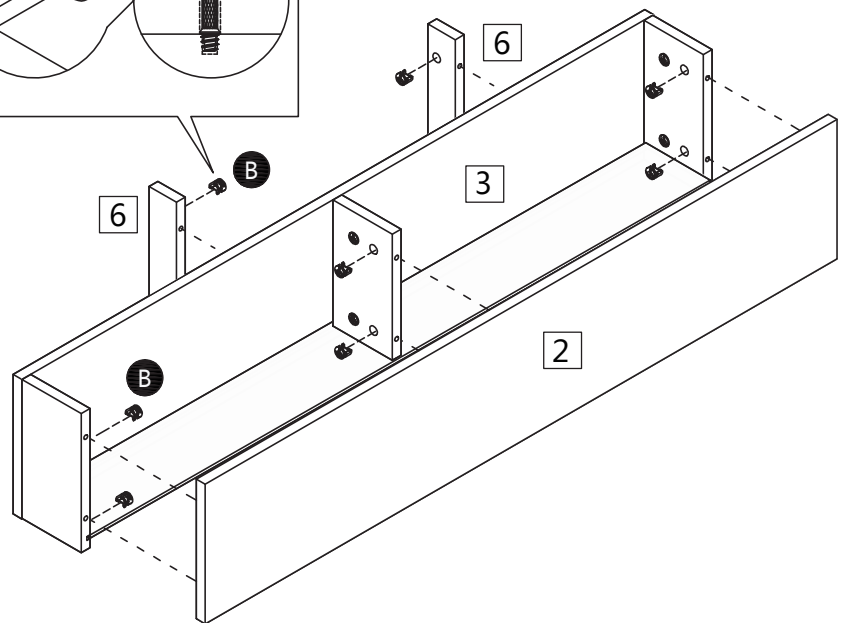
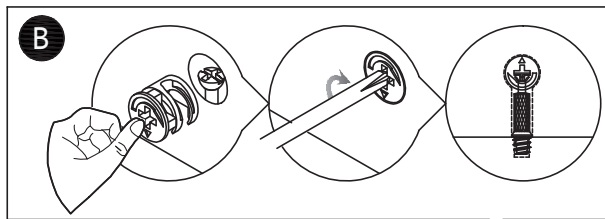

Assembly Steps

Step 5

Use self adhesive covers **C** to cover fixing holes.

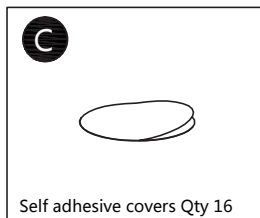
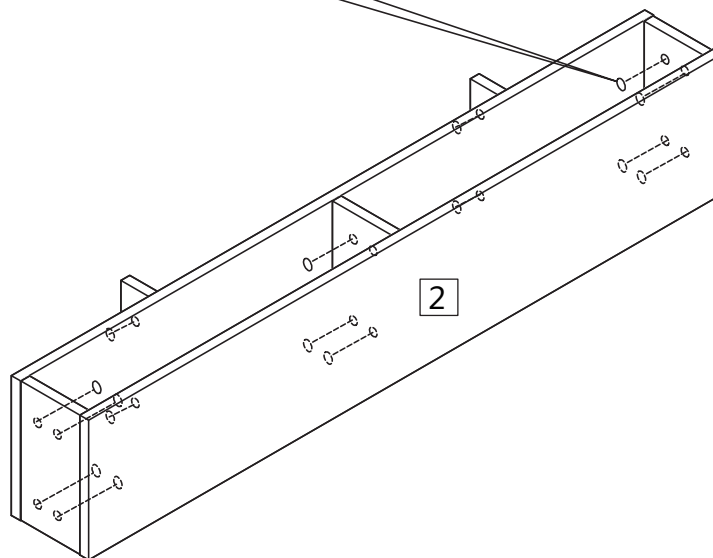
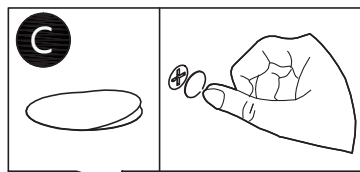

Step 6

IMPORTANT
Push wireless charging coil **L** firmly down.
Maintain pressure and turn central knob to secure

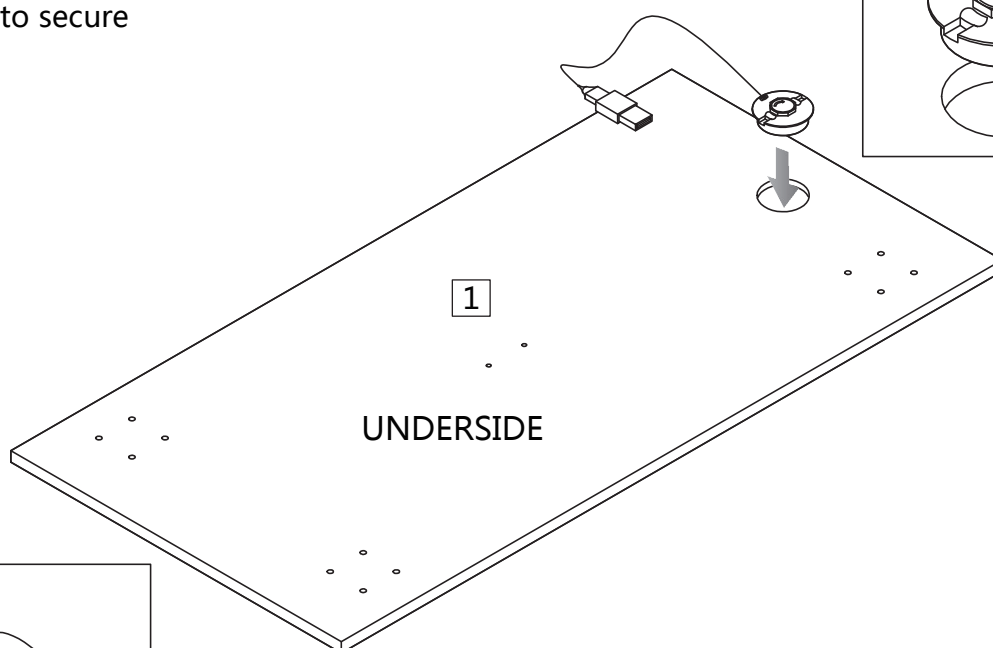
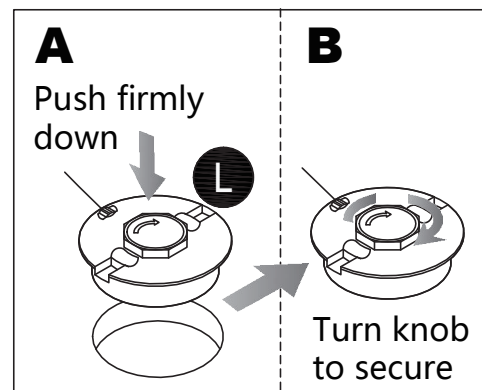

Shown upside down.

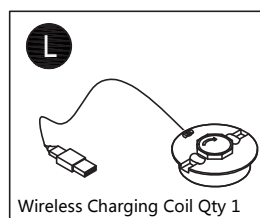



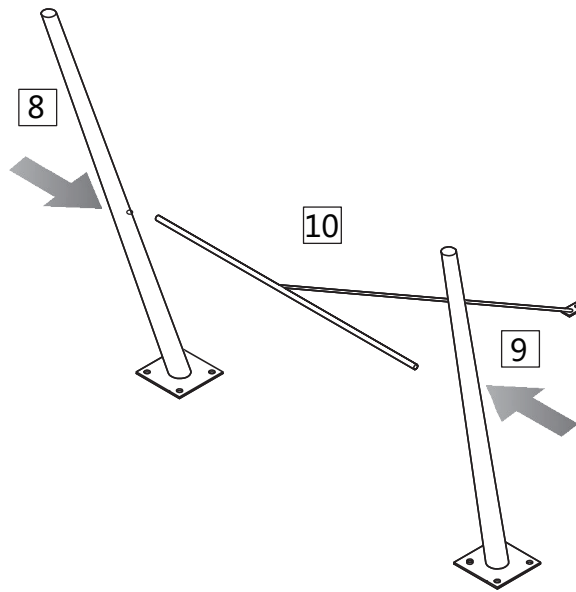

Assembly Steps

Step 7

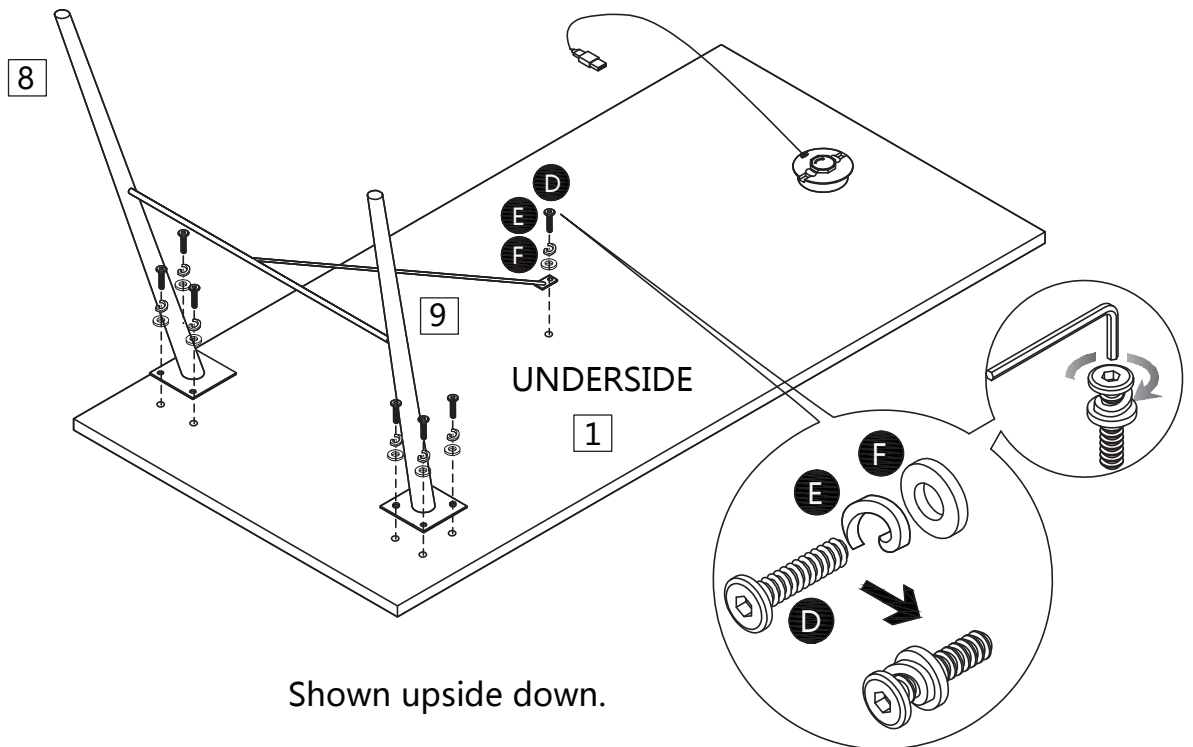

Step 8





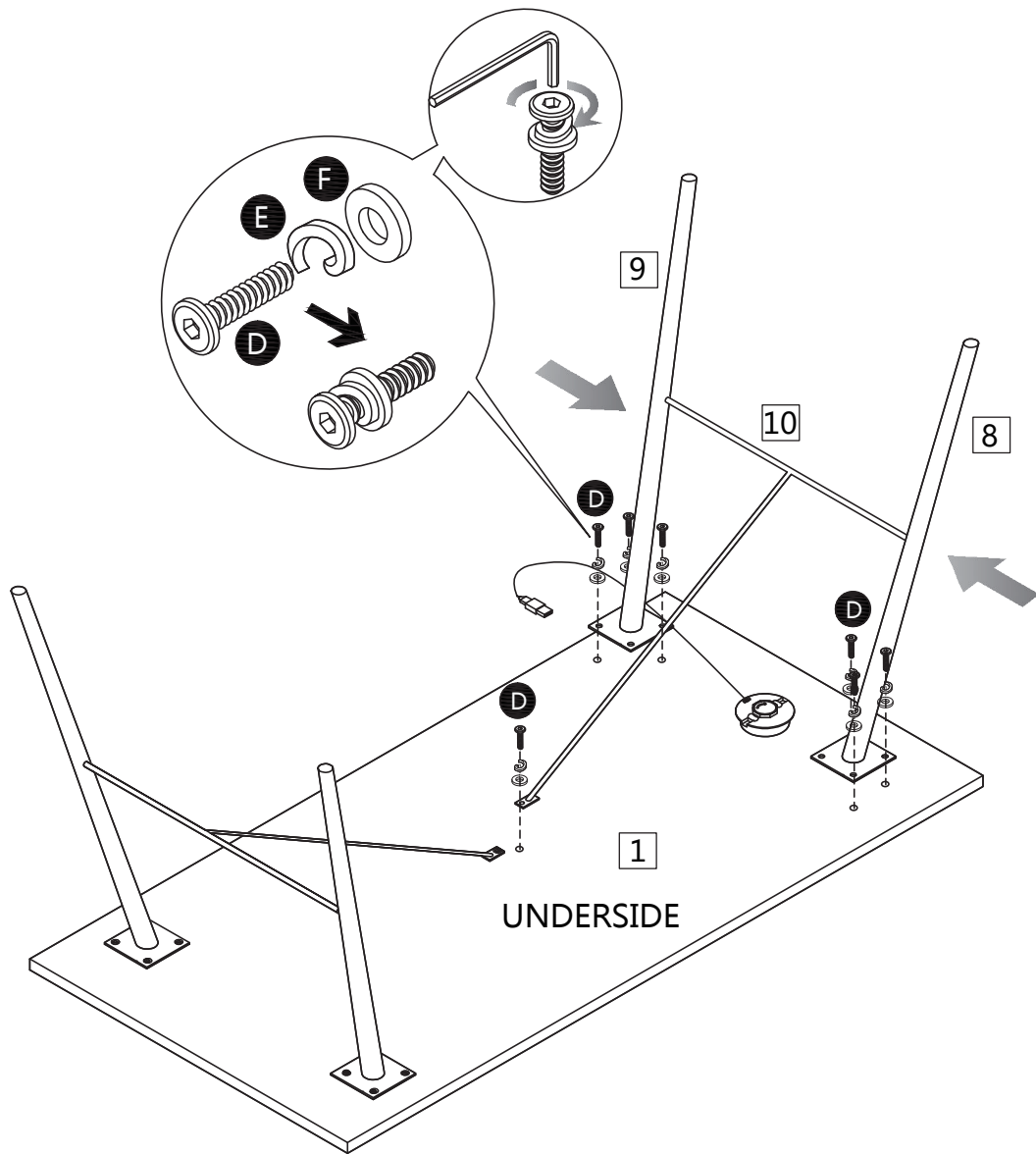

D 	E 	F 	N 
M6*16 Allen Screw Qty 7	M6 Split Lock Washer Qty 7	M6 Washer Qty 7	M4 Allen Key Qty 1

Assembly Steps

Step 9



Shown upside down.

D 	E 	F 	N 
M6*16 Allen Screw Qty 7	M6 Split Lock Washer Qty 7	M6 Washer Qty 7	M4 Allen Key Qty 1

Assembly Steps

Step 10

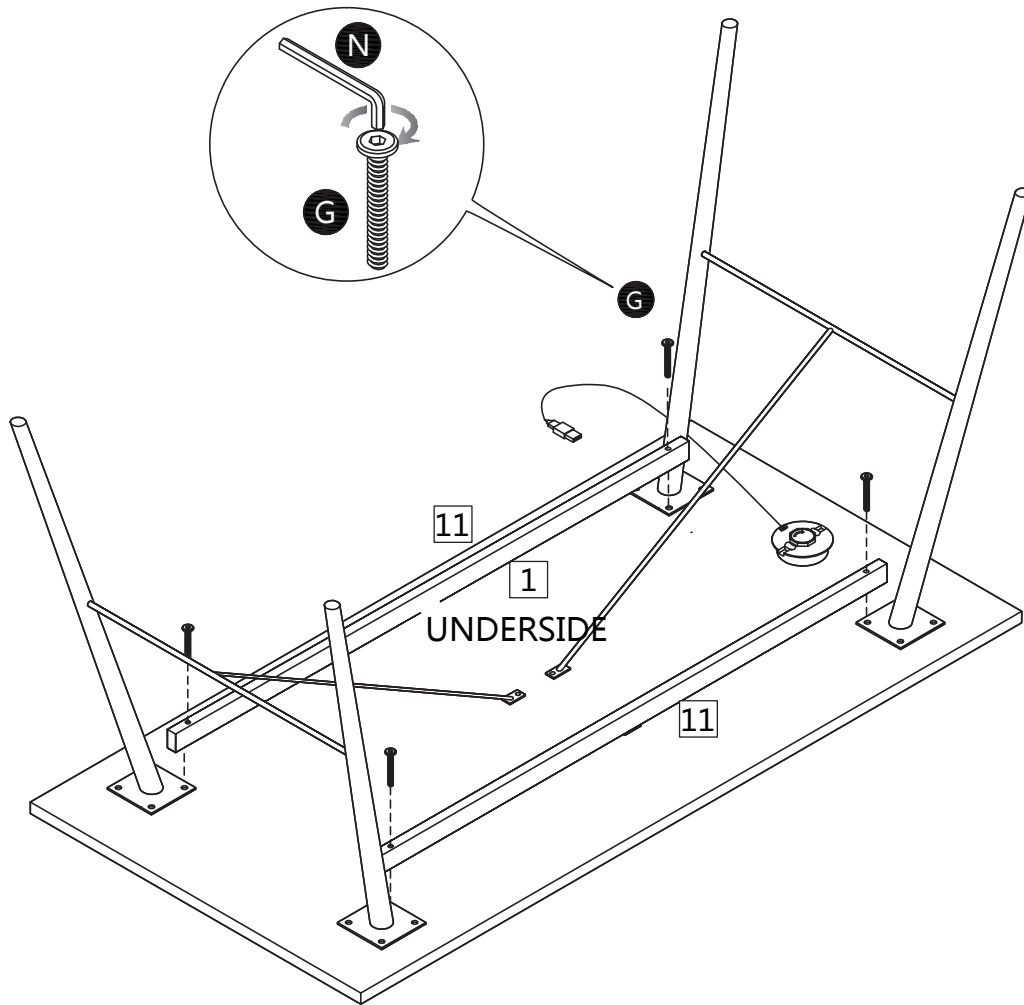

Shown upside down.

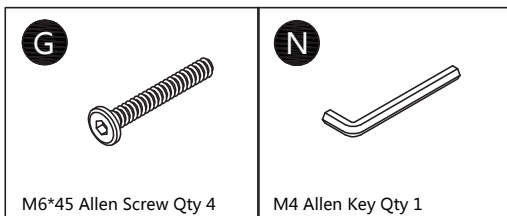

Assembly Steps

Step 11

Two people required!!

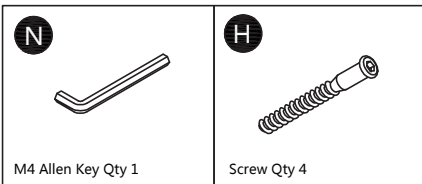
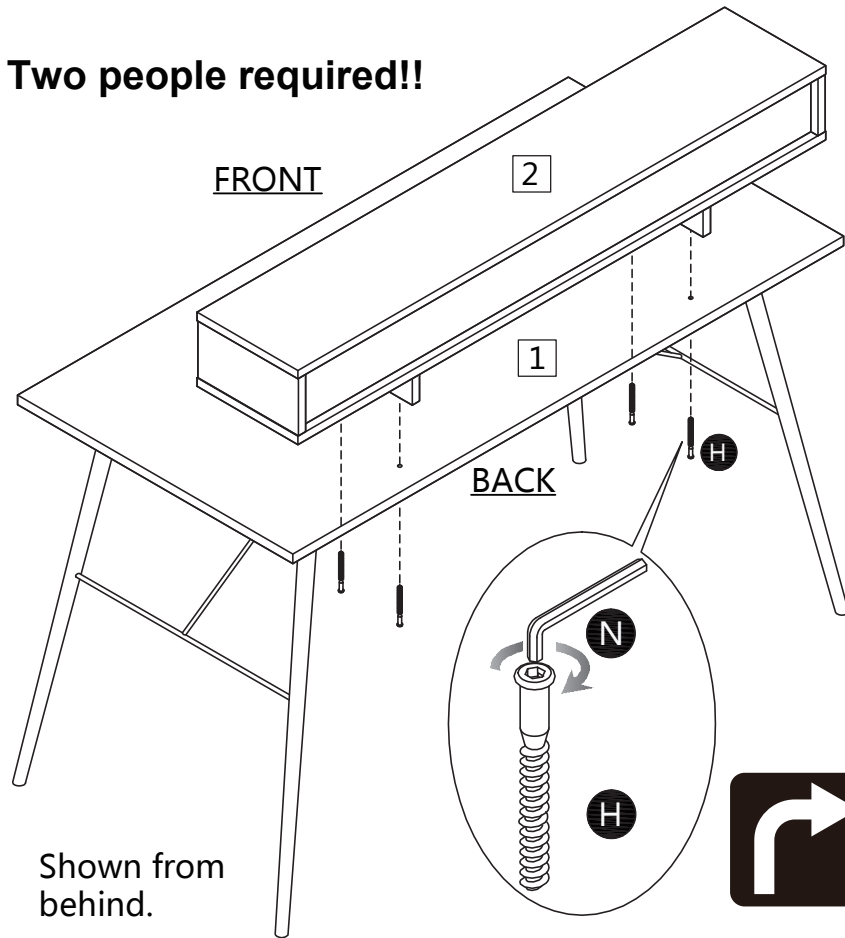

Step 12

Use Cable Clips (M) to route the power cable as required

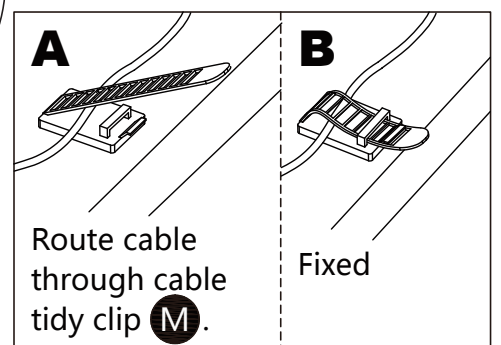
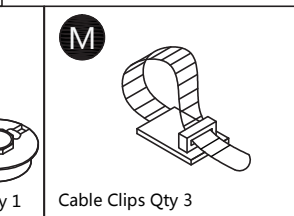
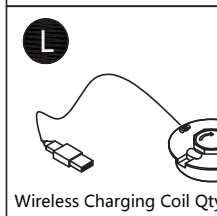
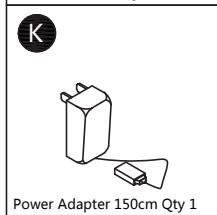
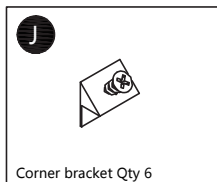
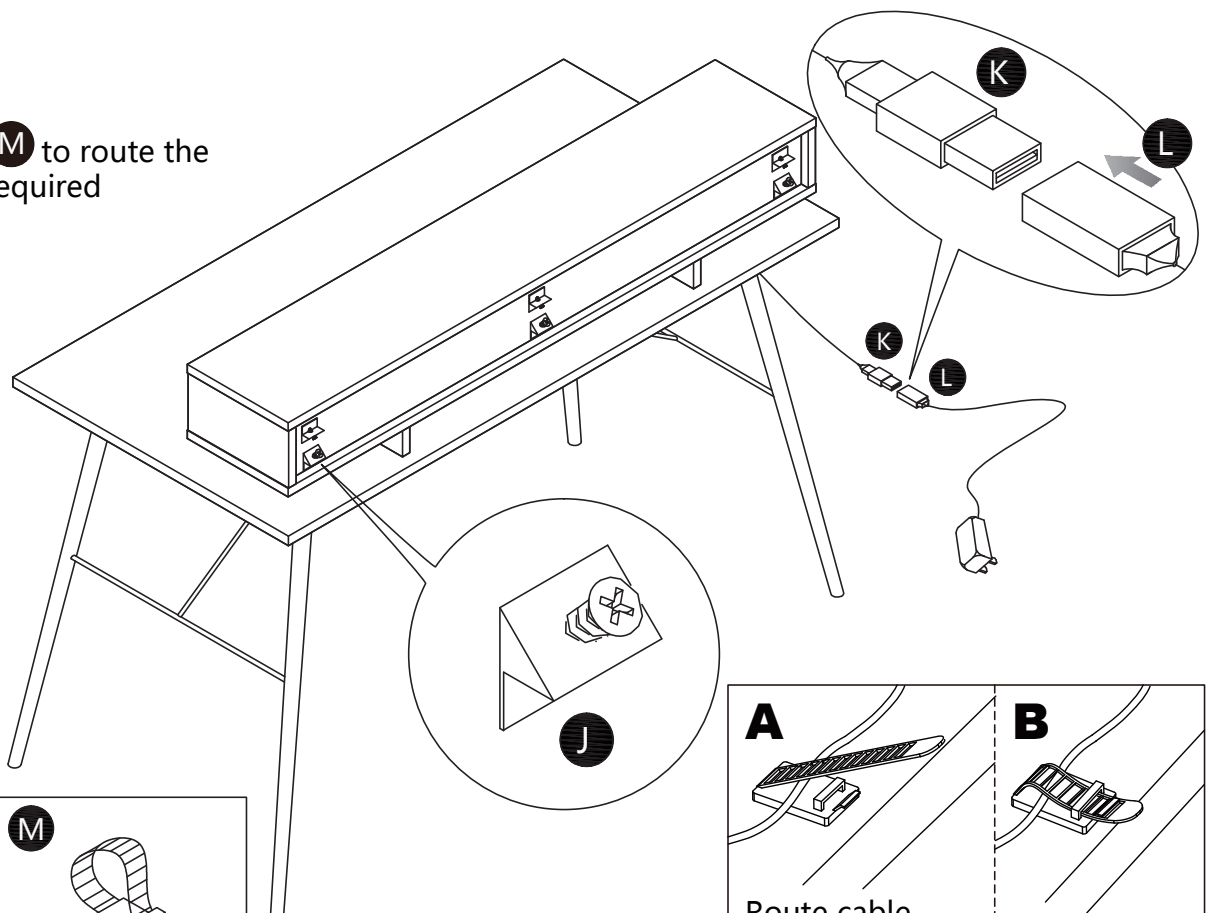

Wireless charging function

If you have a wireless charging compatible phone, please put the phone on the wireless charging indicator and check if the phone is successfully connected to the charging function. If not, move the mobile phone around the logo until the connection is successful.

Some phone cases may inhibit the wireless charging function or its efficiency. It may be necessary to remove the phone case if difficulties with charging are experienced.

Wireless charging will only work with wireless charging compatible mobile devices.

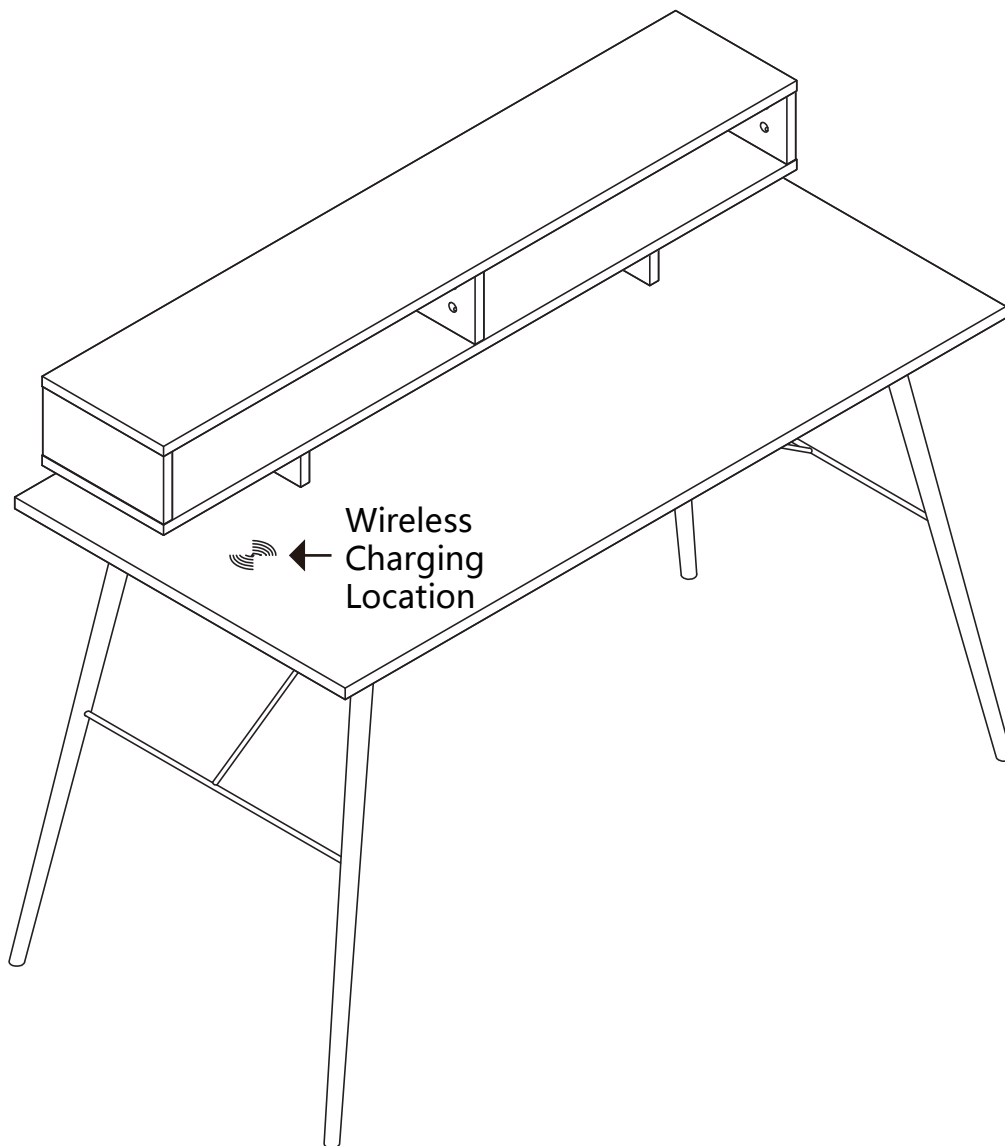

Technical Specification

Working voltage: DC DC 5V/2A

Wireless Charging:5W

Power Supply: AC adapter,100-240V~50/60Hz

Safety and Care Advice

- 1.The maximum weight that can be placed on this product is 30KG
- 2.This product must not be used as a seat.
3. Always use the original AC power adapter and power cable, otherwise it may cause slow wireless charging,In extreme cases,an incompatible AC power adapter may burn out.
4. In order to avoid accidents, do not open any electrical covers. Refer to a professional if the circuit is faulty.
- 5.Do not expose the product to damp or moisture.
- 6.Keep the product away from containers holding liquid.If any liquid enters into the product, it may be damaged.
- 7.Do not expose the product to dust or smoke.
- 8.If the product will not be used for a long time,please unplug the power.
9. When using the product ,if smoke appears,or if there is a peculiar smell,please turn off the power,pull out the socket and seek professional help.
- 10.Pull out the plug before cleaning the surface of the product. It can be cleaned with a damp cloth and soap.

Function

Wireless charging function

Trouble shooting

If any failure occurs, please refer to the following solutions, to help solve the problem.
If these are of no help, please contact the customer service helpline.

PROBLEM	PROBLEM CAUSE	REMEDY
No power display	Power plug not inserted properly. There is no power in the socket. The power is not switched on.	Check plug. Check power supply. Turn on the power socket.
No wireless charging	Power not connected. Mobile device does not have wireless charging function.	Check power is connected and on. Check your mobile device has wireless charging capability. Remove any cover from your mobile device.

Disposal



If disposal of this product becomes necessary, please do this in an environmentally responsible way. Contact your local government office or authority for suitable disposal or recycling options in your local area. Do not dispose of this product, or its components, with your general domestic waste.

After Sales Support / Product Returns

Purchased from kobledesigns.com

In the unlikely event that you need to return the unit because it is faulty, please follow the replacements or faulty items instructions at www.kobledesigns.com website.

Should you need to request replacement parts, please contact our after sales support team at:-

Email - CS@kobledesigns.com

Tel: + 44 (0)1799 513 466

Address: Koble Designs, 6 The Shires, Shirehill industrial Estate, Saffron Walden, Essex, CB11 3AP

Purchased from other retailer

If you purchased your product from one of our retail partners, please refer back to the retailer directly, for any customer services related issues, refunds or returns requests.

Koble designs may still be able to offer support with technical related queries.