

Safety Information

>All electrical work must be undertaken by a qualified contractor to ensure compliance with latest edition BS7671 and IEE/IET wiring regulations.

> Before installing the Ashley LED Panel Light or doing any maintenance, ensure power supply is turned off at the circuit breaker or fuse box.

> This product is designed for permanent connection to fixed wiring; the circuit should be protected with the appropriate MCB or fuse.

Environment

>Please DO NOT dispose of electrical items or packaging as unsorted waste. Use the recycling facilities provided by your local authorities.

Important Warranty Information

The Ashley LED Panel Light has a 3 year warranty, which can be extended free of charge to 5 years by registering online via the website address below. The registrant must provide the product part number and date of manufacture, which can be found on the label attached to the luminaire housing.

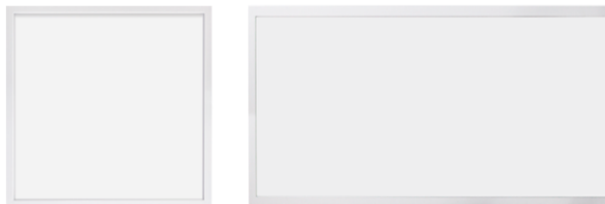

Certificate No. FS 590684



Certificate No. EMS 590685

NETLED Lighting
Buckingway Business Park
300 Anderson Road
Cambridge
CB24 4UQ
sales@netled.co.uk
www.netled.co.uk

Technical Helpline: 01223 851505
Email: support@netled.co.uk

www.netled.co.uk/downloads

Distributed by



ASHLEY LED PANEL INSTALLATION GUIDE

Tri-Colour Options:

Part Number:	Description:
NET-43-03-72	300x300mm Standard
NET-43-03-82	500x500mm Standard
NET-43-03-77	300x600mm Standard
NET-43-03-65	600x600mm Standard
NET-43-03-20	600x600mm Standard
NET-43-03-95	1200x300mm Standard
NET-43-03-30	1200x600mm Standard

Single Colour (4000K) Options:

Part Number:	Description:
NET-43-03-60	600x600mm Standard
NET-43-03-50	1200x600mm Standard

PRODUCT DIMENSIONS

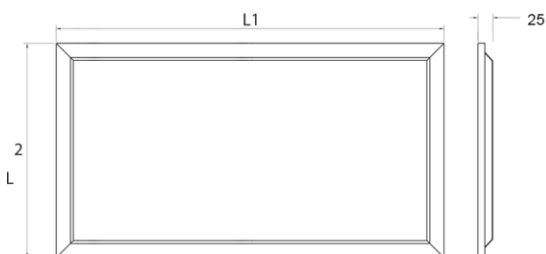

Size(mmxmm)	L1	L2
295x295	295	295
495x495	495	495
295x595	295	595
595x595	595	595
1195x295	1195	295
1195x595	1195	595

All units are in mm

SUPPLY/EARTH CLASS

Driver
220-240V AC 50/60 Hz
Fig.1 Mains Input Termination

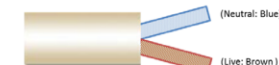

Class II

30-42V DC
Luminaire

Fig2. Twist Lock Connectors





Class III



Installation procedure: Carefully read the installation instructions and ensure the mains supply is isolated before installation. Please follow the safety information overleaf before carrying out any installation. Please retain the leaflet for future reference. Important: When installing, leave a space of at least 1.2m between the LED Panel and any heating source/air conditioning unit.

LED Panel Installation:

 Non-Replaceable light source  Replaceable control gear by professional

Step 1: Carefully remove the LED Panel and driver from the packaging. Remove the ceiling tile from the location where you want to install the LED Panel.

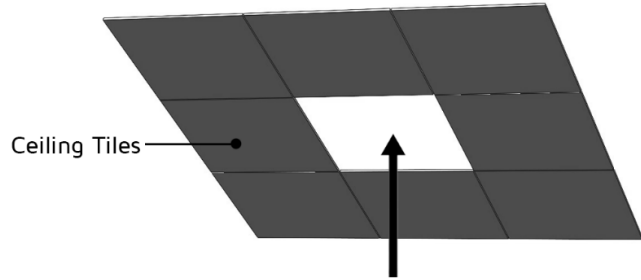

Fig.1

Step 2: Wire the flying leads from the LED Driver into the mains supply, Fig.2.

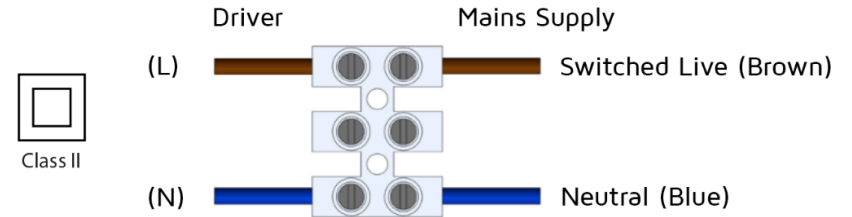

Fig.2

Step 3: Connect the panel light and driver, Fig.3.

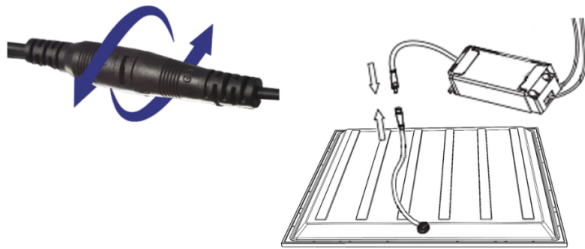

Fig.3

Step 4: Move the LED Panel into the ceiling grid aperture and ensure the LED Panel is mounted securely, Fig.4a. Finally, turn on the mains supply to check the panel is working correctly, Fig.4b.

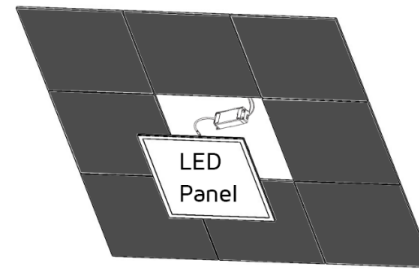

Fig.4a

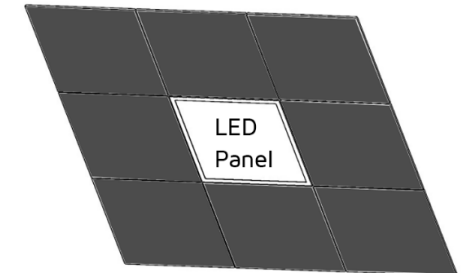
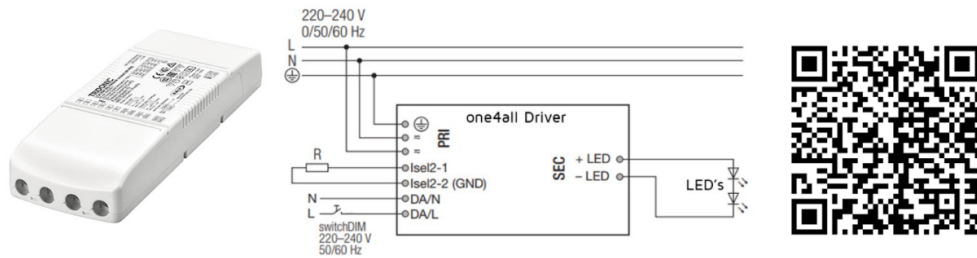

Fig.4b

Alternate wiring diagrams

Dimmable LED Panel wiring diagram:



For more Dimmable and Dimmable Emergency information, please refer to the above QR code for driver wiring instructions.

Emergency wiring diagram:

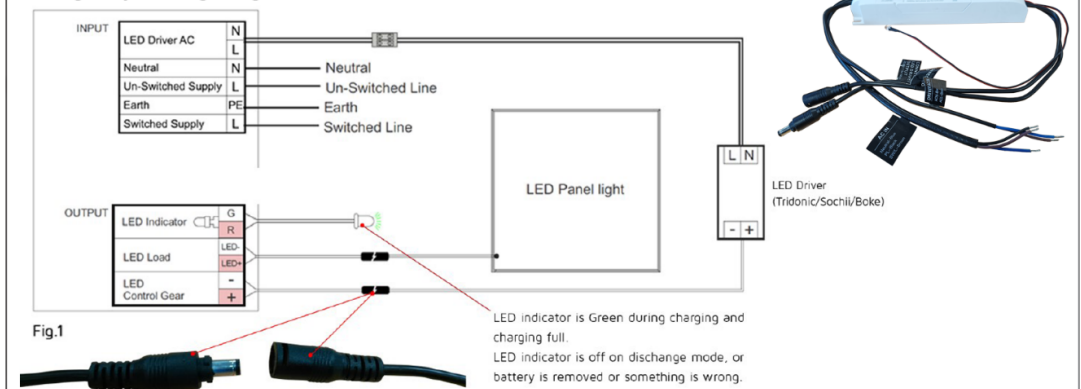

Fig.1

Safety Information:

- The dimming cables should be run separately from the connections and mains cables to ensure good EMC conditions.

Wiring the plug-in terminal:

- Use solid wire or stranded wire with the correct cross-section
- Strip off correct length of insulation; you may need to twist the tool slightly
- If stranded wire is used: push onto the terminal from above to be able to insert the wire
- Insert the bare end into the terminal

Detaching the plug-in terminal:

- Push onto the terminal from above to release the wire
- Pull out the wire at the front

Mains supply wires
Stranded with or solid wire from
0.5 to 2.5mm² may be used for
wiring.

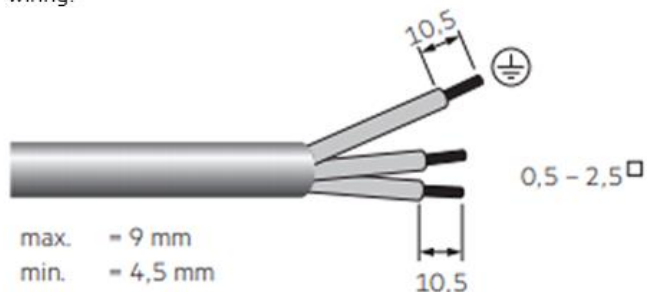

For more information regarding driver settings/options, please access the QR code below:



Tridonic LCA PRE, LC EXC



Certificate No. FS 590684



Certificate No. EMS 590685

TRIDONIC

Dimming Driver
Installation Guide

Distributed by
NET LED
LIGHTING



NET LED Lighting
Buckway Business Park
300 Anderson Road
Cambridge
CB24 4UQ
sales@netled.co.uk
www.netled.co.uk

Technical Helpline: 01223 851505
Email: support@netled.co.uk

www.netled.co.uk/downloads
PRD-40-10-81

Installation procedure: Carefully read the installation instructions and ensure the mains supply is isolated before installation. Please follow the safety information overleaf before carrying out any installation. Please retain this leaflet for future reference.

DALI

Description:

DALI (Digital Addressable Lighting Interface) is an interface protocol for digital communication between electronic lighting equipment.

DALI offers a lot of possibilities:

- DALI line: 64 LED Driver can be grouped to a line
- DALI groups: Every LED Driver can be attributed into 16 groups
- Addressability: All LED Driver are individually addressable
- Grouping: Possible without complicated rewiring
- Programmability: Individual programmability makes it possible to use functions which transcend the DALI standard
- Monitoring: Easily possible thanks to status feedback
- Wiring: Simple wiring with five pole standard cables and a cable length of max. 300 metres
- Wiring: Polarity-free control lines can be used for mains and control lines
- Wiring: Multiple wiring possibilities (star, series and mixed wiring)
- Unaffected by interruptions: All luminaires receive the same, unaffected digital signal and dimming level
- Similar light level from first to last luminaire.

Technical data of a DALI line:

- DALI voltage: 9.5V - 22.4V
- Maximum DALI system current: max. 250mA
- Data transfer rate: 1200 Baud
- Maximum line length: up to 300m (for 1.5mm²)

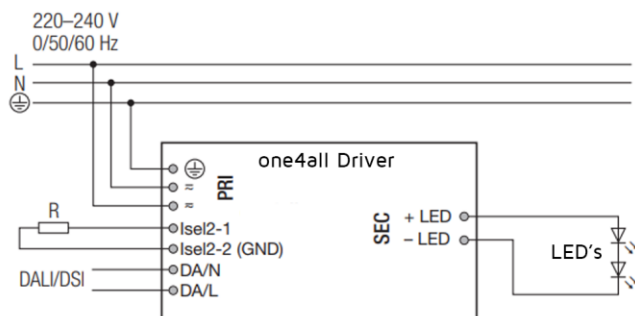

switchDIM/Push

Description:

With the switchDIM function it is possible to use the mains voltage as a control signal.

The phase of a standard mains voltage push button is connected to the terminal marked DA/L and the neutral conductor is connected to the terminal marked DA/N.

Using the function is easy and convenient:

- A short press (50-600 ms) switches the device on or off
- A long press (>600 ms) fades the connected operating device alternately up and down (between 1 and 100%)

The device has a switchDIM memory function. This is used, among other things, for storing the last dimming value in the event of interruptions in the power supply.

When power returns, the LED is automatically restored to its previous operating state and dimmed to the last value.

⚠ Caution!

Glow switches are not approved for controlling switchDIM.

Glow switches may cause the LED Driver to spontaneously switch on or off or make sudden changes in the dimming value.

⚠ Caution!

A maximum number of 25 operating devices per switchDIM system should not be exceeded.

If you have more devices please use DALI.

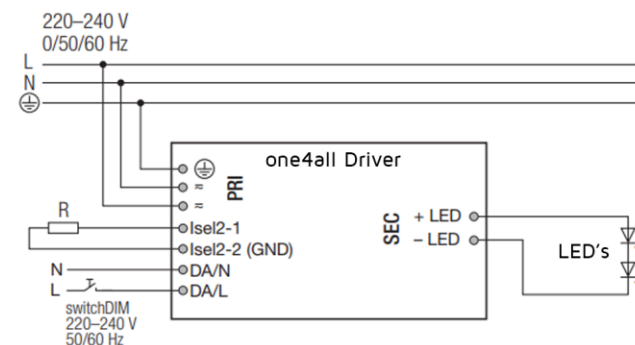

Safety Information

>All electrical work must be undertaken by a qualified contractor to ensure compliance with latest edition BS7671 and IEE/IET wiring regulations.

> Before installing the Emergency kit or doing any maintenance, ensure power supply is turned off at the circuit breaker or fuse box.

> This product is designed for permanent connection to fixed wiring; the circuit should be protected with the appropriate MCB or fuse.

Environment

>Please DO NOT dispose of electrical items or packaging as unsorted waste. Use the recycling facilities provided by your local authorities.

PRODUCT DIMENSIONS

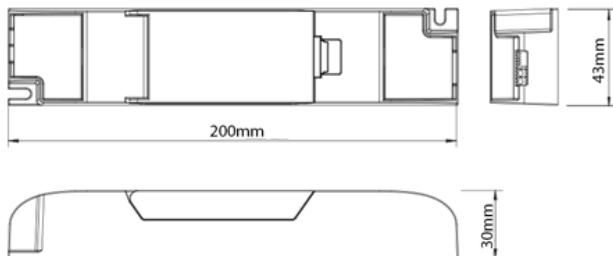

Important Warranty Information

The Emergency Lighting Kit has a 3 year warranty. To claim you must provide the product part number and date of manufacture, which can be found on the label attached to the luminaire housing along with the original purchase invoice.



Certificate No. FS 590684



Certificate No. EMS 590685

NET LED Limited
Buckwing Business Park
300 Anderson Road
Cambridge
CB24 4UQ UK
sales@netled.co.uk
www.netled.co.uk

Technical Helpline: 01223 851505
Email: support@netled.co.uk

www.netled.co.uk/downloads

Distributed by



Streamer LED Emergency Converter for Panels & Downlights

NET-50-12-08

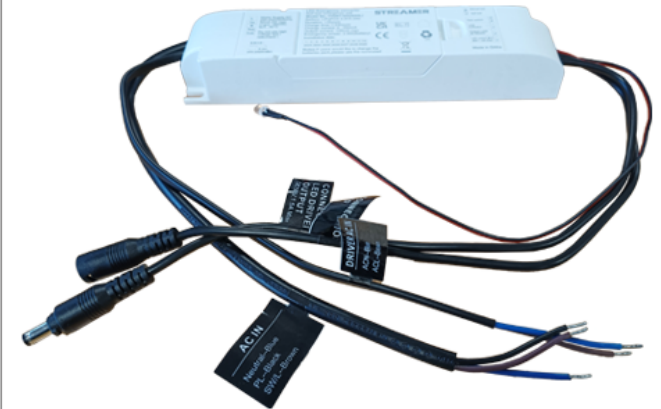

SUPPLY/EARTH CLASS

Driver

220-240V AC 50/60 Hz
Fig.1 Mains Input Termination

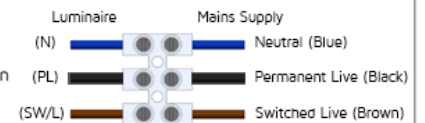

Luminaire

36-42V DC
Fig2. Twist Lock Connectors



Installation procedure: Carefully read the installation instructions and ensure the mains supply is isolated before installation. Please follow the safety information overleaf before carrying out any installation. Please retain this leaflet for future reference.

Step 1: Wiring Connection Details

Remove the Emergency Kit from the packaging.
 Connect the Emergency Kit to the LED Panel following the wiring guide which shows the typical wiring of the Emergency kit.
 The Emergency Kit must have a connection to an unswitched supply originating from the same supply as the mains lighting in the area in which it is to be installed.
 When wiring is complete, ensure the cables are secured in place using the fixings supplied.

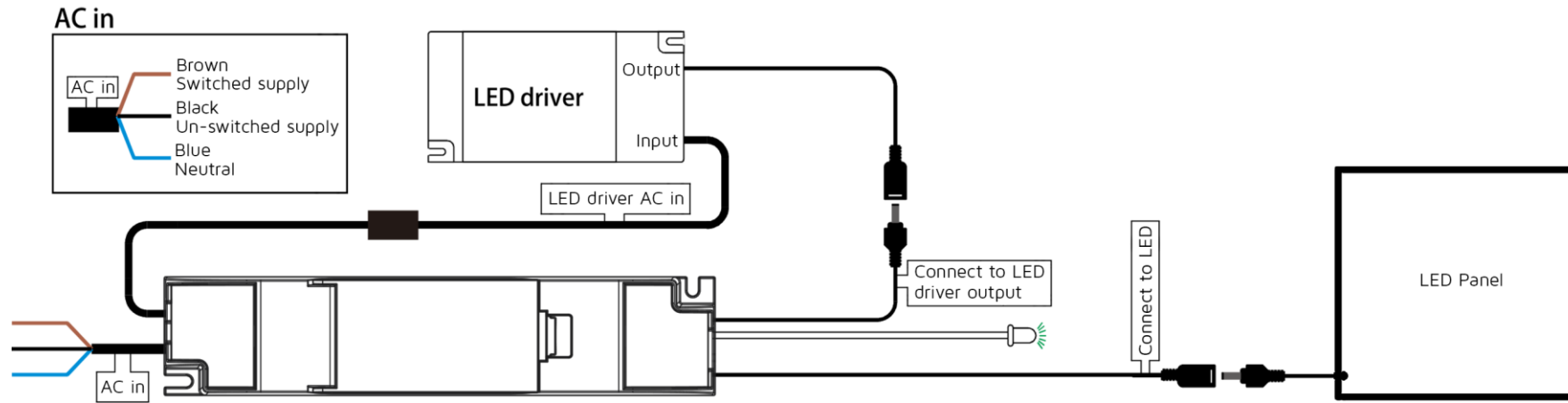

Step 2: Apply Mains Supply

Apply mains supply to test the LED tube. The indicator LED will show green.

NOTE: The indicator LED must be visible when the fitting is in normal use, in accordance with BS EN 60598-2-22.

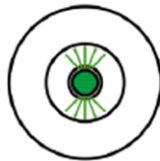

Step 3: Test Emergency Supply

To test, briefly fail the unswitched and mains supply to illuminate fitting from the internal battery. The indicator LED will be extinguished and the LEDs on the Tube will illuminate.

NOTE: If the battery has not been charged for an extended period, the luminaire may only illuminate briefly or fail to operate until the battery is charged.



General Description

- Luminaire should only be installed by suitably qualified personnel.
- Installation should be carried out in accordance with the requirements of BS7671 and luminaires located as required by BS5266 Pt. 1 as well as BS EN 1838 and BS EN 50172.
- Before installing, connecting or servicing these luminaires, isolate the mains supply to which they are to be connected.
- To comply with the requirements of BS EN 50172, it is necessary to record the indicator LED status.

Technical Specifications	
Power	2.5W
Input Voltage AC	220-240V
Power Factor	>0.5
Output Voltage	DC 10-50V
Output Power	2.5W
Battery Pack	LiFePO4 3.2V 2000Ah
Battery Cut-off	5V
Recharge Period	24H
Hours Maintained	>3H
Operating Temperature	0°C to +50°C
Weight	0.285Kg

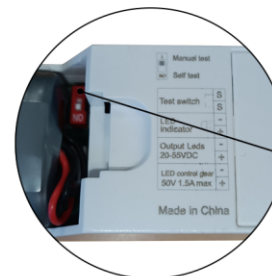

The Emergency kit can be switched from Manual Test to Self Test by selecting the required setting with the DIP Switch under the access hatch.

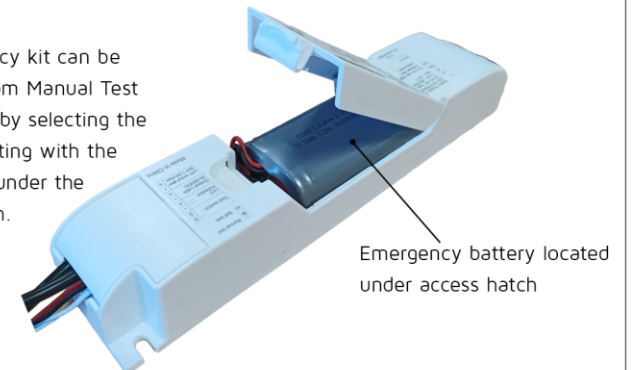

Self-test

The emergency kits carry out self-tests automatically to ensure its functionality. The self-test includes 3 types of tests:

Initial test

- As soon as mains supply is connected, the emergency kit will carry out a functional test automatically for 3-seconds.
- In case of a failure, the LED will turn permanent red. Otherwise, the charge mode will start.

Functional test

- Refers to charging, discharging and the functioning of load.
- Carried out for 10 seconds automatically every 30 calendar days.

Duration test

- Refers to the test of batteries capacity.
- Carry out every 180 calendar days.

Rest mode







Rest mode can be initiated during emergency mode by pressing test switch longer than 3 seconds. The rest mode will be exited automatically after AC mains is reconnected.

Please note

If mains supply is off during self-test period, emergency conversion module would terminate self-test immediately and go into emergency mode.

Self-test is under the regulation of EN 62034.

Explanation of LED indicator

	Colour	LED indication	Status	Comment
	Green	Slow flashing green (3 sec on, 1 sec off)	Charging Mode	AC mode
	Green	Permanent green	Fully Charged	AC mode
	Green	Fast flashing green (0.1 sec on, 0.1 sec off)	Function test underway	
	Green	Slow flashing green (1 sec on, 1 sec off)	Duration test underway	
	Red	Permanent red	Load failure	Open circuit/Short circuit LED failure (emergency mode)
	Red	Slow flashing red (1 sec on, 1 sec off)	Battery failure	Battery failed the duration test or function test/No battery
		Green and red off	DC mode	Battery operation (emergency mode)

Sheet Number	Site			
Test types:	C = Commissioning and verification test			
	M = Monthly test (see BS EN 50172) short function test			
	A = Annual test (BS EN 50172) full rated duration test			
Date of test	Test Type	Result - Test passed	Result - Test failed	
		No action needed	Need for repair of system notified	Need for safeguarding of premises notified
		Name	Name	Name
	C			
	M - 1st Month			
	M - 2nd Month			
	M - 3rd Month			
	M - 4th Month			
	M - 5th Month			
	M - 6th Month			
	M - 7th Month			
	M - 8th Month			
	M - 9th Month			
	M - 10th Month			
	M - 11th Month			
	A - ___ Year			
	M - 1st Month			
	M - 2nd Month			
	M - 3rd Month			
	M - 4th Month			
	M - 5th Month			
	M - 6th Month			
	M - 7th Month			
	M - 8th Month			
	M - 9th Month			
	M - 10th Month			
	M - 11th Month			
	A - ___ Year			
	M - 1st Month			
	M - 2nd Month			
	M - 3rd Month			
	M - 4th Month			
	M - 5th Month			
	M - 6th Month			
	M - 7th Month			
	M - 8th Month			
	M - 9th Month			
	M - 10th Month			
	M - 11th Month			
	A - ___ Year			